

SAFCO®

# TECHWORKS®

Price List and Specification Guide



# OVERVIEW/GENERAL INFORMATION

## ABOUT SAFCO®

SAFCO® empowers leading organizations across industries and disciplines with flexible workplace solutions that are fast, curated, and complete. We know that time equals money. That's why we are committed to supporting our dealer partners and independent sales reps with products and services that allow them to stay focused on building customer relationships.

We help by approaching ideas in new ways with furniture solutions that adapt to the speed of change and withstands the rigors of continuous exploration such as TechWorks®, a robust modular system consisting of exceptionally strong, ergonomically responsive, and diverse components that offer ultimate flexibility for reconfiguration and ease of future growth. Robust custom capabilities and design services drive further value for our customers.

TechWorks is manufactured in our state-of-the-art facility in Milford, IA. This plant allows us to build our legacy products more effectively and enables new product design innovation for the future. Our headquarters is in Minneapolis, MN.

## TECHWORKS STANDARD FINISH OPTIONS

The chart below represents the standard material options, but reference appropriate finishes available for each product on the respective product page. Online or printed samples may vary depending on your monitor and printer. Contact your local SAFCO sales representative or order actual samples from our website: [safcoproducts.com/product/fabric-and-finishes](http://safcoproducts.com/product/fabric-and-finishes)

### POWDER COAT FINISHES



### WORK SURFACES AND EDGE BANDS



### FABRIC FINISHES

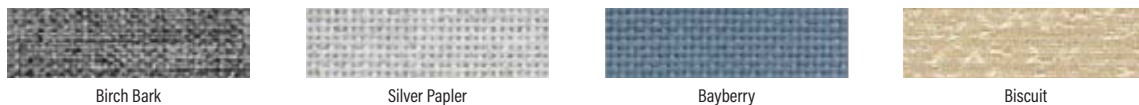

## GUIDE TO PAGES & ORDERING

### GENERAL

This catalog serves as a general guide for ordering TechWorks. Our goal is to give you the knowledge you need to comfortably bring SAFCO's TechWorks collection to life for any project size and application.

TechWorks offers a versatile kit of parts with modular components that can be adjusted, added to, and reconfigured easily to significantly reduce downtime and save organizations money.

### HOW TO SPECIFY

- Several typical options are available as easy-to-specify options, simply select your finish options.
- Or follow the easy-to-specify instructions throughout this price list to guide you through the specification process.

### 5 EASY STEPS

1. Select bench and work surface	2. Select an organizer frame to match bench width	3. Select shelves	4. Select accessories	5. Select finishes
				Powder coat paint color Work surface Fabric options (See options on pg. 2)

### HOW TO ORDER

Purchase orders should be submitted to [orders@safcoproducts.com](mailto:orders@safcoproducts.com). If a space planning or special price quote was provided, your purchase order must reference that quote number to ensure your order is processed accurately.

TechWorks orders will be scheduled with our manufacturing plant and a ship date will be provided on your order acknowledgment. If any information is missing, a member of our Customer Service team will reach out with questions.

### PRODUCT DETAILS ILLUSTRATIONS, DIMENSIONS AND WEIGHTS

This catalog serves as a general guideline for ordering. The product descriptions provide a brief overview of what the product is, what it does, and what it includes. The illustrations are provided for reference and may not be an exact depiction of each product. All dimensions and weights listed are based on the latest information available at the time of publication.

### PRODUCT NUMBERS

When ordering, please use the complete product number for the appropriate product, including finishes, and any other specifying information provided in the notes of each section.

### PRICES

Prices are provided in U.S. dollars and represent the published List Price only. SAFCO reserves the right to change the published List Pricing at any time without prior notice. All orders with future ship dates must reflect current pricing within 180 days.

### LEAD TIMES

SAFCO publishes current lead times within our sales portals. If you do not have a login to our sales portal, please contact Customer Service at (888) 971-6225 or email [info@safcoproducts.com](mailto:info@safcoproducts.com).

## GUIDE TO PAGES & ORDERING (CONTINUED)

### SPACE PLANNING / DESIGN AND QUOTING SERVICES

Our team of experts provide workspace and storage solutions design services, bid/quote assistance, and order and specification support, to enable our partners to win more opportunities and deliver the best solutions to their customers. Contact your local SAFCO sales representative for more information:

[safcoproducts.com/rep-locator](http://safcoproducts.com/rep-locator)

- For space planning requests for larger, complex projects, simply fill out the TechWorks Survey form and submit along with an Auto CAD drawing of the room or space, to [spaceplanning@safcoproducts.com](mailto:spaceplanning@safcoproducts.com)
- For assistance with bids and special pricing requests, submit to [bids@safcoproducts.com](mailto:bids@safcoproducts.com)
- For custom product requests, submit to [specials@safcoproducts.com](mailto:specials@safcoproducts.com)

### INSTALLATION SERVICES

If you need assistance installing SAFCO products, a list of certified installers can be found on our website: [safcoproducts.com/installation-services](http://safcoproducts.com/installation-services)

Our in-house installation Manager can help with questions to ensure your project goes smoothly from the time your product arrives until the very last piece of hardware is in place.

### COPYRIGHT INFORMATION

- SAFCO® and TechWorks® are registered trademarks of SAFCO®
- Please call, fax, or email us with any questions you may have about this catalog or our products

Toll Free: (888) 971-6225

Fax: (763) 971-1525

Email: [info@safcoproducts.com](mailto:info@safcoproducts.com)

---

## SALES & ORDER POLICIES

### CASH TERMS

1% - 15 Net 30. For cash discount, remittance must be made 15 days following invoice date. Net amount due 30 days following invoice date.

### FACTORY RETURNS

All TechWorks orders are considered custom (made-to-order) and cannot be returned.

### ORDER CANCELLATION

Orders that have entered any stage of production cannot be canceled. Requests for cancellation are not accepted until acknowledged by SAFCO.

If a cancellation request is accepted by SAFCO, cancellation charges may apply.

### FREIGHT DAMAGE

All shipments must be carefully inspected upon receipt by the assigned freight forwarder to ensure all items are in satisfactory condition before signing the bill of lading. If there is visible damage or shortage, it must be noted on the bill of lading. If not noted, we will be unable to file a claim with the carrier due to their policies. Visible damage or shortage must be reported within 24 hours of receipt of goods by the freight forwarder.

### DESIGN

We reserve the right to make changes in design and material, as well as discontinuance of parts and units, when such action is deemed to be an improvement in design, function and/or construction.

## FREIGHT POLICY

### FREIGHT - EFFECTIVE JANUARY 3, 2022

Prepaid on all orders of \$1,500 Net or more.

Orders less than \$1,500 Net:

LTL: \$150 Flat rate

Small Parcel: \$25 Flat rate

Orders containing both LTL and small parcel: \$150 flat rate

### MINIMUM ORDERS

No minimum order requirement, however, all orders must be placed in full carton quantities.

Special routing request fees for LTL (Accessorial Charges):

- Call before Delivery – Included. Please specify at order entry.
- Lift Gate Assistance – \$125 for orders requiring a lift gate (no loading dock).
- Inside Delivery – \$50 for delivery to threshold only of first door.
  - Does not include put in place, un-carton, assembly, or trash removal.
  - Local restrictions may apply.
- Additional redelivery or storage charges may apply if special routing requests are not specified ahead of time and additional trips are required.
- Contact [projectmanagement@safcoproducts.com](mailto:projectmanagement@safcoproducts.com) for a quote on Expedited Service (guaranteed date and time of delivery), or larger volume orders or special services requested over 2,000 lbs.
- Safco is not responsible for issues or costs arising from carrier transit delays, missed delivery appointments, etc.

## QUALITY & WARRANTY STATEMENTS

### STATEMENT OF QUALITY

At SAFCO®, we understand that quality extends beyond simple function, and we are committed to the highest level of satisfaction in the manufacture, sale, and support of our products. From concept to delivery, we integrate high levels of quality as our standard and work hard to impress our customers every day. We strive for continuous improvements in all areas of product and service by regarding our quality programs as an integral part of the company's improvement process. Safco's quality program works to provide products that meet or exceed the quality standards our customers expect. We aim to set high environmental and safety standards by offering a large collection of third-party tested products that meet standards set forth by BIFMA, UL, the State of California, and others.

### ENVIRONMENTAL COMMITMENTS

SAFCO not only holds itself to strict environmental standards, but we also require suppliers to follow these standards as a total supply chain initiative. Suppliers play an important role in our longstanding commitment to perform operations in a manner consistent with sound health, safety, and environmental management practices. Because of this, suppliers are not only expected to comply with applicable health, safety and environmental laws and regulations, they are expected to seek continuous improvement within these realms. Safco continues to become an environmentally conscious company with the intention to offer more products that our customers can feel good about, and responsible practices that encourage sustainability, helping us obtain a proud standing in our community and the planet.

### OPERATIONS

SAFCO advocates continuous improvement in the realms of efficient recycling and/or disposal of waste materials and improving treatment and control of waste emissions affecting air, water, and soil. We also encourage the practice of waste reduction operations such as machine efficiency, raw material utilization, conservation of soil, air, water quality, biodiversity, wildlife and aquatic habitats, the practice of sustainable forest management policies where applicable, end-of-life treatment recommendations, raw material and recycled content regulation, and legal compliance with environmental legislation.

### LIMITED LIFETIME WARRANTY

Our warranty pledges excellence in the quality of our products. It helps protect our customers' investments and extends our continuing dedication to our customers after their initial investment.

Download our Warranty Statement here: [safcoproducts.com/resources/warranty-statement](http://safcoproducts.com/resources/warranty-statement)

Please keep all purchase documents for the product in event the warranty is needed. Contact our Customer Service team for any warranty assistance at [info@safcoproducts.com](mailto:info@safcoproducts.com) or (888) 971-6225.

### CUSTOM PRODUCT REQUESTS

All requests for customization of product, sizes, or non-standard finishes must have prior approval by SAFCO's Specials Department before purchase order submission. Please email [specials@safcoproducts.com](mailto:specials@safcoproducts.com) for approval. Limited Lifetime Warranty does not extend to custom products.

# BUILD YOUR TECHWORKS BENCH

## DESIGNED FOR CHANGE

Growth comes from embracing innovation and being able to adapt at the speed of change. TechWorks® helps organizations approach ideas in new ways by offering complete flexibility to support change and unmatched durability to withstand the rigors of continuous exploration. It's the optimal solution for connecting people with the art of discovery.

You can create layouts where teams can easily come together to share resources and ideas. Adjustability and mobility drive efficiency, support well-being, and enhance workflow. Let's get started.

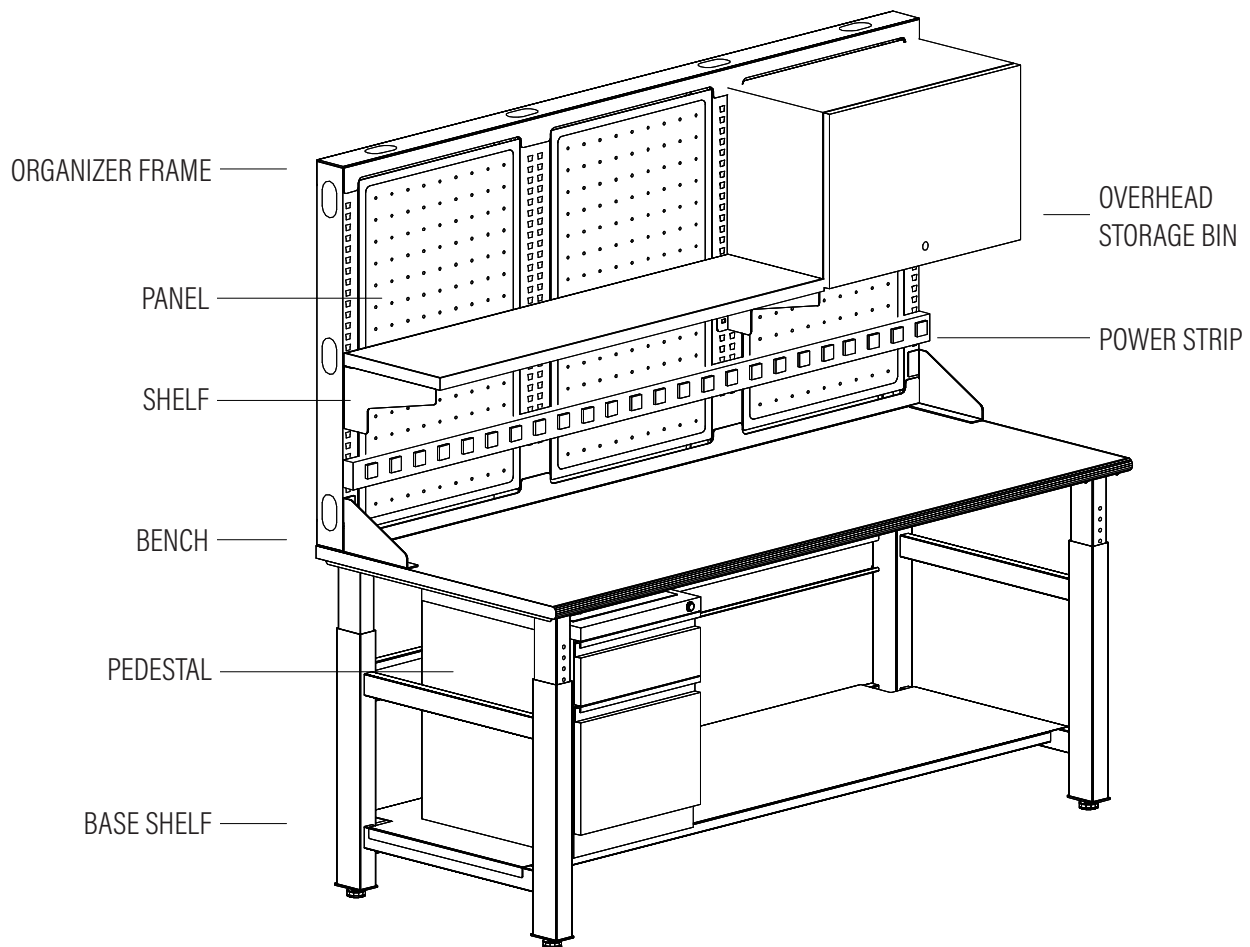

**TYPICALS  
IDEA STARTERS**

PAGES 8-13

**BENCHES & TABLES**

PAGES 14-27



**ORGANIZER FRAMES**

PAGES 28-33



**SHELVING**

PAGES 34-41

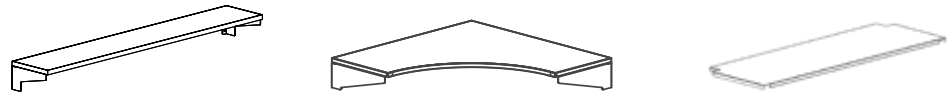

**ORGANIZER FRAME PANELS**

PAGES 42-47

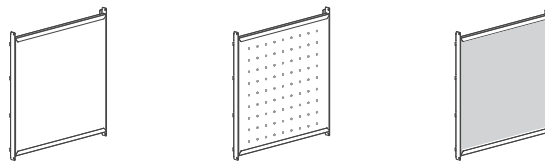

**STORAGE OPTIONS**

PAGES 48-53

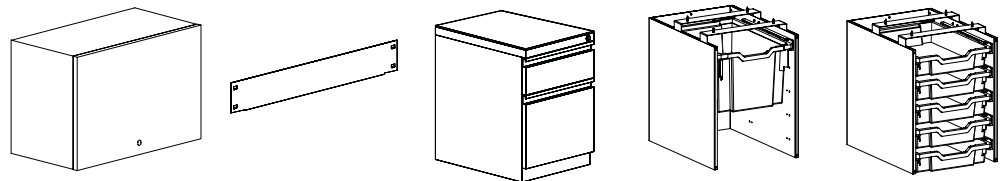

**STORAGE CENTER**

PAGES 54-55

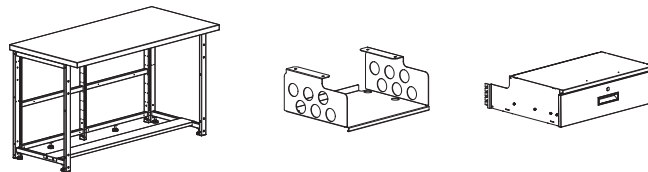

**POWER ACCESSORIES**

PAGES 56-59

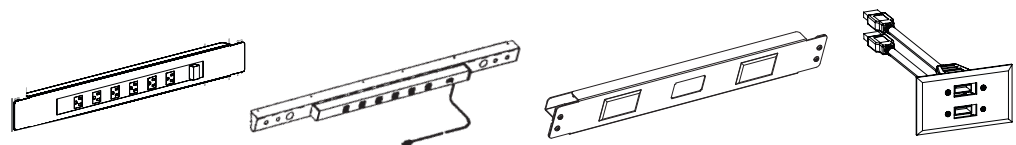

**OVERHEAD & TASK LIGHTING**

PAGES 60-61

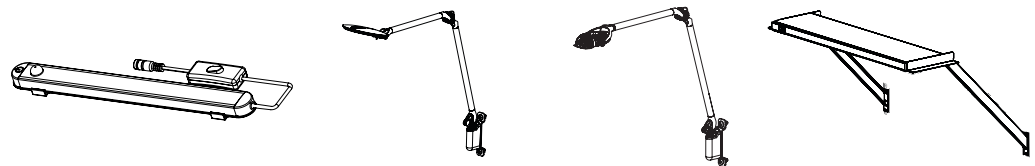

**ACCESSORIES**

PAGES 62-65

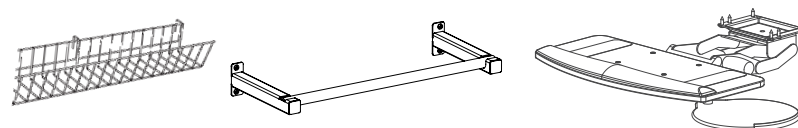

**INDEX**

PAGES 66-67

## TYPICAL 1

Quantity	Model No.	Description	Ext. List Price
1	TWB7224BB	72"W x 24"D Adjustable Straight Bench with Butcher Block Surface	3,296.00
2	TWDRWR	Utility Drawer with Lock	1,482.00
<b>TWTYP1</b>			<b>4,778.00</b>



## TYPICAL 2

Quantity	Model No.	Description	Ext. List Price
1	TWB4824H3	48"W x 24"D Adjustable Straight Bench with High Pressure Laminate Surface	2,202.00
1	TWUF4836	48"W x 36"H Organizer Frame	1,118.00
1	TWFS4812H3	48"W Fixed Shelf, High Pressure Laminate	786.00
1	TWSPW4815	48"W, 15 AMP Power Strip, 16 Outlets, 15' Cord	590.00
1	TWM1	Single Screen Monitor Arm	180.00
1	TWCASKIT4	Caster Kit (4)	275.00
<b>TWTYP2</b>			<b>5,151.00</b>



## TYPICAL 3

Quantity	Model No.	Description	Ext. List Price
1	TWB7224BB	72"W x 24"D Adjustable Straight Bench with Butcher Block Surface	3,296.00
1	TWUF7224	72"W x 24"H Organizer Frame	1,260.00
1	TWWB2424	24"W x 24"H Whiteboard Panel	390.00
1	TWPGM2424	24"W x 24"H Peg Board Panel, Masonite	390.00
2	TWDRWR	Utility Drawer with Lock	1,482.00
<b>TWTYP3</b>			<b>6,818.00</b>





**TYPICAL 4**

Quantity	Model No.	Description	Ext. List Price
1	TWB7230H3	72"W x 30"D Adjustable Straight Bench with High Pressure Laminate Surface	2,665.00
1	TWUF7248	72"W x 36"H Organizer Frame	1,487.00
1	TWFS7218H3	72"W x 18"D Fixed Shelf, High Pressure Laminate	1,283.00
1	TWWB2436	24"W x 36"H Whiteboard Panel	475.00
2	TWBINSTP24	24"W x 3"H Part Bin Panel	280.00
1	PH20SW	Suspended Pedestal, Box/File	784.00
1	TWSPW7215	72"W, 15 AMP Power Strip, 24 Outlets, 15' Cord	740.00

**TWTYP4**

**7,714.00**



**TYPICAL 5**

Quantity	Model No.	Description	Ext. List Price
2	TWB6030BB	60"W x 30"D Adjustable Straight Bench with Butcher Block Surface	7,132.00
1	TWUF6048	60"W x 48"H Organizer Frame	1,356.00
4	TWFS6012H3	60"W x 12"D Fixed Shelf, High Pressure Laminate	3,512.00
2	TWPBS6012	Partial Base Bench Shelf	806.00
1	TWWB3048	30"W x 48"H Whiteboard Panel	579.00
1	TWPGM3048	30"W x 48"H Peg Board Panel, Masonite	585.00
2	TWTLB	Basic Task Light	1,122.00
2	TWSVB60	Service Bar 60" 15 AMP Power Strip, 12 Outlets, 15' Cord	1,820.00
1	TWSHUFKIT	Back-to-Back Shared Organizer Frame Hardware Kit	195.00

**TWTYP5**

**17,107.00**



## TYPICAL 6

Quantity	Model No.	Description	Ext. List Price
1	TWBHA60H3	60"W x 30"D Electric Adjustable-Height Bench with High Pressure Laminate Surface	7577.00
1	TWUF6048	60"W x 48"H Organizer Frame	1,356.00
1	TWPGM3048	30"W x 48"H Peg Board Panel, Masonite	585.00
1	TWWB3048	30"W x 48"H Whiteboard Panel	579.00

TWYP6

10,097.00



## TYPICAL 7

Quantity	Model No.	Description	Ext. List Price
1	TWBC4830H3	48"W x 30"D Adjustable Corner Bench with High Pressure Laminate Surface	3,144.00
1	TWUCF4848	48"W x 48"H Organizer Corner Frame	2,132.00
1	TWCS4812H3	12"D x 48"W Corner Shelf, High Pressure Laminate	1,309.00
2	TWSPW2415	24"W, 15 AMP Power Strip, 8 Outlets, 15' Cord	1,038.00

TWYP7

7,623.00



## TYPICAL 8

Quantity	Model No.	Description	Ext. List Price
1	TWB7230ES	72"W x 30"D Adjustable Straight Bench with ESD Laminate Surface	3,795.00
1	TWUF7248	72"W x 48"H Organizer Frame	1,487.00
2	TWFS7218ES	18"D x 72"W Fixed Shelf, ESD Laminate Surface	3,238.00
1	PH20SM	Mobile Pedestal, Box/File	625.00
1	TWM2	Dual Screen Monitor Arm	277.00
1	TWSPW7215	72"W, 15 AMP Power Strip, 24 Outlets, 15' Cord	740.00
1	TWDA24	Telecom Channel	253.00
1	TWESDGRBAR	ESD Grounding Bar	248.00
1	TWESDGRJK	ESD Grounding Jack	159.00
1	TWESDWR	ESD Wrist Strap	145.00

TWYP8

10,967.00

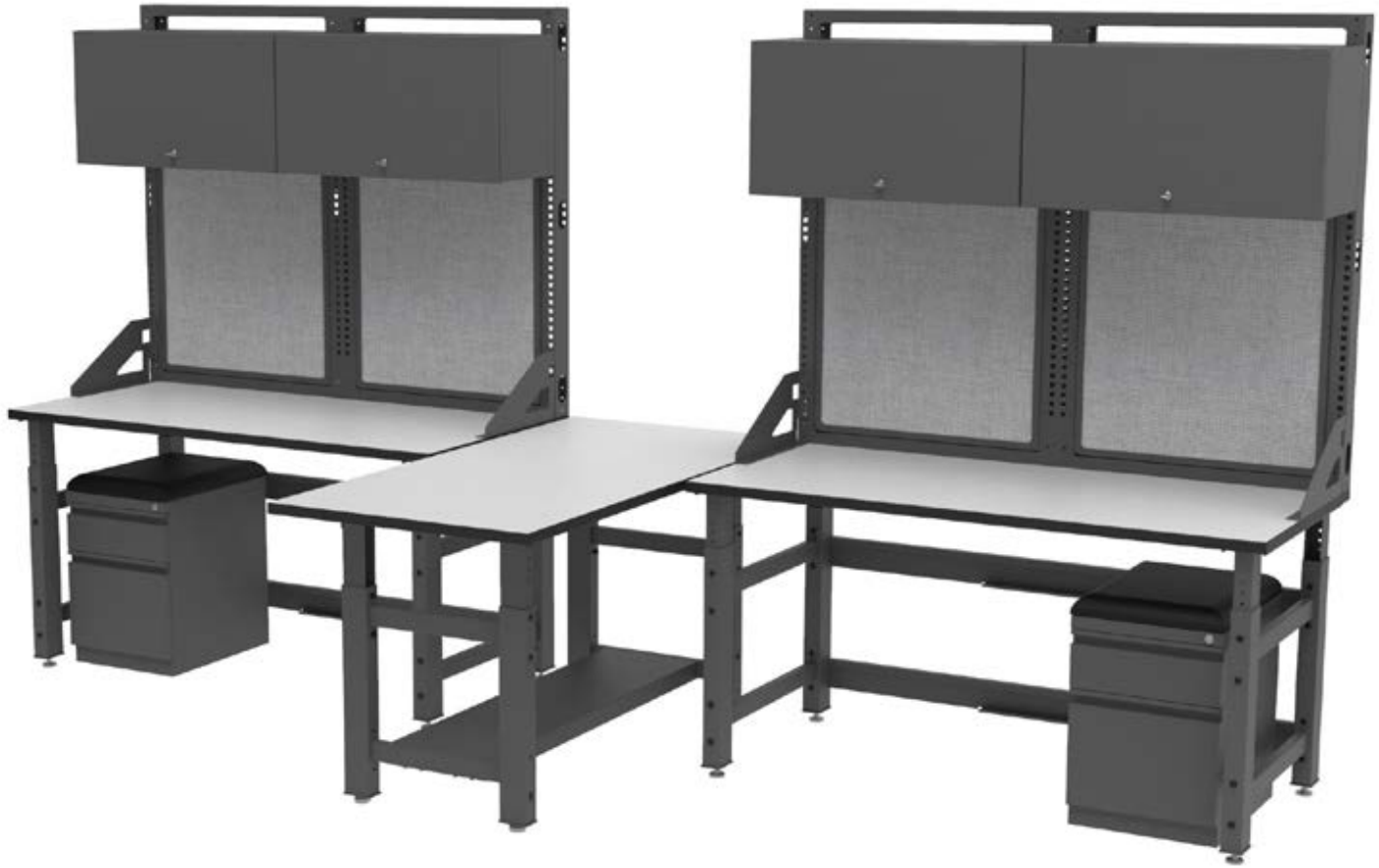

**TYPICAL 9**

Quantity	Model No.	Description	Ext. List Price
1	TWT6030ES	60"W x 30"D Adjustable Table with ESD Laminate Surface	3,830.00
2	TWB6030ES	60"W x 30"D Adjustable Straight Bench with ESD Laminate Surface	7,528.00
2	TWUF6048	60"W x 48"H Organizer Frame	2,712.00
4	TWOHST30	30"W x 12"D x 16"H Lockable Storage Bin	6,548.00
4	TWFP3036	30"W x 36"H Fabric Screen Panel	2,452.00
2	PH20SM	Mobile Pedestal, Box/File	1,250.00
2	CSH20	Faux Leather Cushion, Black	664.00
3	TWESDGRBAR	ESD Grounding Bar	744.00
3	TWESDGRJK	ESD Grounding Jack	477.00
3	TWESDWR	ESD Wrist Strap	435.00

**TWTYP9****26,640.00**

**TYPICAL 10**

Quantity	Model No.	Description	Ext. List Price
1	TWT7230H3	72"W x 30"D Adjustable Table with High Pressure Laminate Surface	2,616.00
1	TWCASKIT4	Caster Kit (4)	275.00
<b>TWTYP10</b>			<b>2,891.00</b>



**TYPICAL 11**

Quantity	Model No.	Description	Ext. List Price
1	TWB7224BB	72"W x 24"D Adjustable Straight Bench with Butcher Block Surface	3,296.00
1	TWUF7224	72"W x 24"H Organizer Frame	1,260.00
1	TWFS7212H3	12"D x 72"W Fixed Shelf, High Pressure Laminate	965.00
<b>TWTYP11</b>			<b>5,521.00</b>



**TYPICAL 12**

Quantity	Model No.	Description	Ext. List Price
1	TWB7230ES	72"W x 30"D Adjustable Straight Bench with ESD Laminate Surface	3,795.00
1	TWUF7248	72"W x 48"H Organizer Frame	1,487.00
2	TWFS7218ES	18"D x 72"W Fixed Shelf, ESD Laminate Surface	3,238.00
1	TWSPW7215	72"W, 15 AMP Power Strip, 24 Outlets, 15' Cord	740.00
1	TWESDGRBAR	ESD Grounding Bar	248.00
1	TWESDGRJK	ESD Grounding Jack	159.00
1	TWESDWR	ESD Wrist Strap	145.00
<b>TWTYP12</b>			<b>9,812.00</b>



**TYPICAL 13**

Quantity	Model No.	Description	Ext. List Price
1	TWB9630H3	96"W x 30"D Adjustable Straight Bench with High Pressure Laminate Surface	4,315.00
2	TWUF4848	48"W x 48"H Organizer Frame	2,538.00
2	TWOHST24	24"W x 12"D x 16"H Lockable Storage Bin	2,700.00
4	TWFS2412H3	12"D x 24"W Fixed Shelf, High Pressure Laminate	2,836.00
2	TWFP2448	24"W x 48"H Fabric Screen Panel	1,474.00
2	PH20SM	Mobile Pedestal, Box/File	1,250.00
2	TWM1	Single Screen Monitor Arm	360.00
2	195TKLS	Keyboard/Mouse Platform	1,718.00
2	TWSPW2415	24"W, 15 AMP Power Strip, 8 Outlets, 15' Cord	1,038.00
2	TWDA24	24"W, Telecom Channel	506.00

**TWTYP13****18,735.00**

# STRAIGHT BENCHES

Benches have 12" of travel range measuring 26" to 38" from the floor to the top of the work surface. Adjusts in 1" increments with threaded fasteners. Benches come standard with leveling glides; optional casters are available (Item TWCASKIT4 - Caster 4 pack) but will add 3" to overall bench height. Benches ship knocked down.

- Benches hold 1,000 lbs. evenly distributed
- Bench standard work surface options include:
  - HPL (High Pressure Laminate 1 1/8" thick) with 3mm PVC edge band on all sides
  - Stainless Steel work-surface is 1 5/8" thick 16GA, type 304, #4 finish with wrapped and welded corners and a particle board core
  - Butcher Block (1 3/4" thick) 1/8" radius on all sides
  - ESD (Electro-Static Discharge 1 1/8" thick) with ground terminus. ESD available in Gray laminate with Black edge banding only (Coordinating accessories available on pg. 65)
- HPL, Butcher Block, and ESD work surfaces come standard with 1 3/4" x 3 1/4" grommet holes (Stainless Steel Benches are NOT available with grommet holes)
- Stainless Steel benches are not compatible with TechWorks organizer frames and accessories and are only available in select sizes (No corner or L-shaped benches)
- Additional colors and work surface materials are available (including phenolic) — upcharges, minimums and extended lead times may apply. Email [specials@safcoproducts.com](mailto:specials@safcoproducts.com) for quotation.

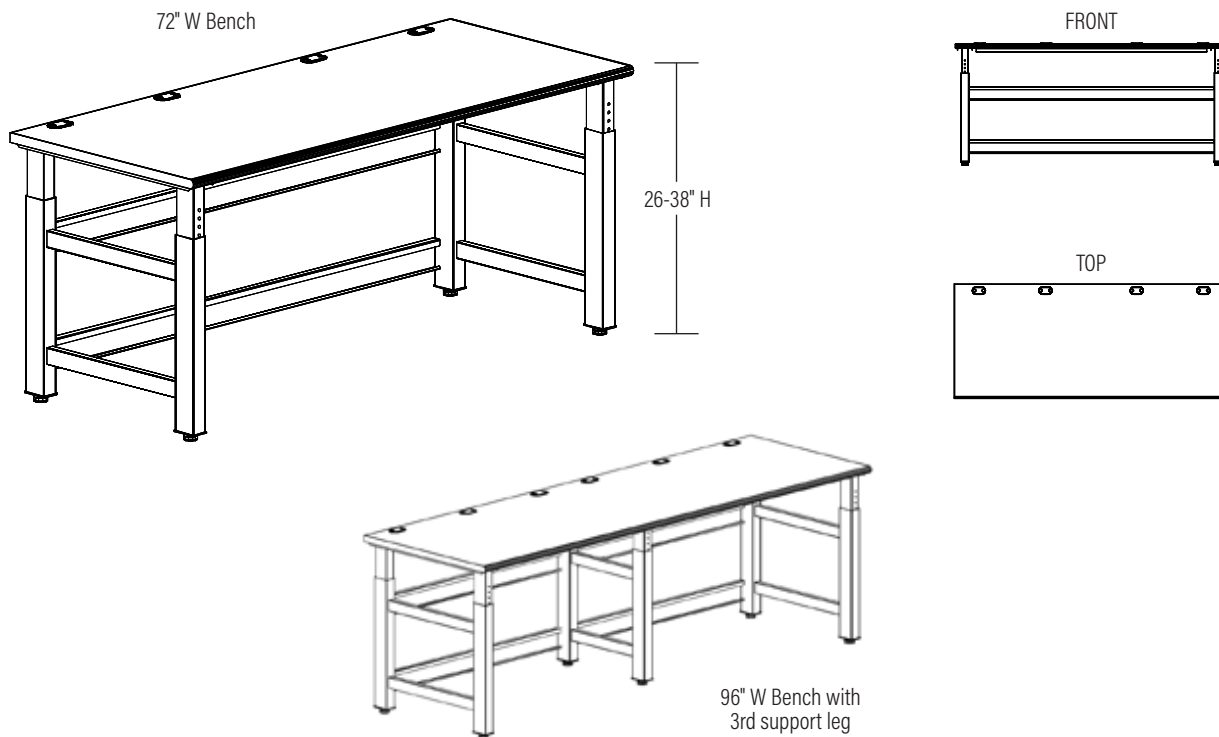

## HOW TO SPECIFY

1. Choose the bench work surface material	2. Choose the bench depth	3. Choose the bench width	4. Choose the bench finish	5. Add optional work surface accessories
HPL	24"	24" 60"	Powder coat paint color	Below work surface accessories (See options on pg. 40)
Stainless Steel	30"	30" 72"	Work surface color if applicable	
Butcher Block	36"	36" 96"	(See options on pg. 2)	Above work surface organizer frame (See options on pg. 28)
ESD*		48"		

\*Includes grounding terminus; coordinating accessories available on pg. 65

Item No.	Description	Weight (lbs.)	List Price
----------	-------------	---------------	------------

## 24"W STRAIGHT BENCH

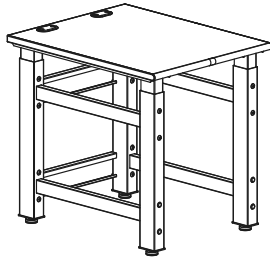

TWB2424H3

### High Pressure Laminate (HPL) Surface

TWB2424H3	24"W x 24"D x 26-38"H Adjustable Bench with High Pressure Laminate Surface	118	1,752.00
TWB2430H3	24"W x 30"D x 26-38"H Adjustable Bench with High Pressure Laminate Surface	120	1,897.00
TWB2436H3	24"W x 36"D x 26-38"H Adjustable Bench with High Pressure Laminate Surface	125	1,998.00

### Stainless Steel Surface

TWB2424SS	24"W x 24"D x 26-38"H Adjustable Bench with Stainless Steel Surface (No Grommets)	130	4,544.00
TWB2430SS	24"W x 30"D x 26-38"H Adjustable Bench with Stainless Steel Surface (No Grommets)	136	4,650.00
TWB2436SS	24"W x 36"D x 26-38"H Adjustable Bench with Stainless Steel Surface (No Grommets)	142	4,745.00

### Butcher Block Surface

TWB2424BB	24"W x 24"D x 26-38"H Adjustable Bench with Butcher Block Surface	124	2,055.00
TWB2430BB	24"W x 30"D x 26-38"H Adjustable Bench with Butcher Block Surface	130	2,363.00
TWB2436BB	24"W x 36"D x 26-38"H Adjustable Bench with Butcher Block Surface	136	2,421.00

### ESD Surface

TWB2424ES	24"W x 24"D x 26-38"H Adjustable Bench with ESD Laminate Surface	118	2,060.00
TWB2430ES	24"W x 30"D x 26-38"H Adjustable Bench with ESD Laminate Surface	120	2,342.00
TWB2436ES	24"W x 36"D x 26-38"H Adjustable Bench with ESD Laminate Surface	125	2,566.00

## 30"W STRAIGHT BENCH

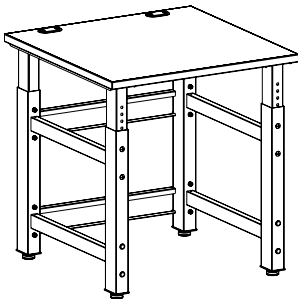

TWB3030H3

### High Pressure Laminate (HPL) Surface

TWB3024H3	30"W x 24"D x 26-38"H Adjustable Bench with High Pressure Laminate Surface	121	1,865.00
TWB3030H3	30"W x 30"D x 26-38"H Adjustable Bench with High Pressure Laminate Surface	128	2,038.00
TWB3036H3	30"W x 36"D x 26-38"H Adjustable Bench with High Pressure Laminate Surface	135	2,124.00

### Stainless Steel Surface

TWB3024SS	30"W x 24"D x 26-38"H Adjustable Bench with Stainless Steel Surface (No Grommets)	135	4,706.00
TWB3030SS	30"W x 30"D x 26-38"H Adjustable Bench with Stainless Steel Surface (No Grommets)	145	4,812.00
TWB3036SS	30"W x 36"D x 26-38"H Adjustable Bench with Stainless Steel Surface (No Grommets)	149	4,907.00

### Butcher Block Surface

TWB3024BB	30"W x 24"D x 26-38"H Adjustable Bench with Butcher Block Surface	135	2,178.00
TWB3030BB	30"W x 30"D x 26-38"H Adjustable Bench with Butcher Block Surface	139	2,504.00
TWB3036BB	30"W x 36"D x 26-38"H Adjustable Bench with Butcher Block Surface	143	2,566.00

### ESD Surface

TWB3024ES	30"W x 24"D x 26-38"H Adjustable Bench with ESD Laminate Surface	121	2,191.00
TWB3030ES	30"W x 30"D x 26-38"H Adjustable Bench with ESD Laminate Surface	128	2,494.00
TWB3036ES	30"W x 36"D x 26-38"H Adjustable Bench with ESD Laminate Surface	135	2,732.00

Item No. Description Weight (lbs.) List Price

### 36"W STRAIGHT BENCH

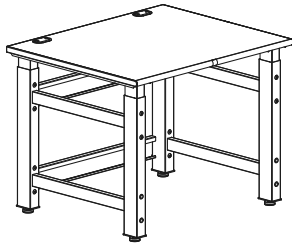

TWB3630H3

#### High Pressure Laminate (HPL) Surface

TWB3624H3	36"W x 24"D x 26-38"H Adjustable Bench with High Pressure Laminate Surface	126	1,981.00
TWB3630H3	36"W x 30"D x 26-38"H Adjustable Bench with High Pressure Laminate Surface	130	2,233.00
TWB3636H3	36"W x 36"D x 26-38"H Adjustable Bench with High Pressure Laminate Surface	142	2,262.00

#### Stainless Steel Surface

TWB3624SS	36"W x 24"D x 26-38"H Adjustable Bench with Stainless Steel Surface (No Grommets)	143	5,028.00
TWB3630SS	36"W x 30"D x 26-38"H Adjustable Bench with Stainless Steel Surface (No Grommets)	146	5,134.00
TWB3636SS	36"W x 36"D x 26-38"H Adjustable Bench with Stainless Steel Surface (No Grommets)	160	5,229.00

#### Butcher Block Surface

TWB3624BB	36"W x 24"D x 26-38"H Adjustable Bench with Butcher Block Surface	137	2,305.00
TWB3630BB	36"W x 30"D x 26-38"H Adjustable Bench with Butcher Block Surface	140	2,650.00
TWB3636BB	36"W x 36"D x 26-38"H Adjustable Bench with Butcher Block Surface	154	2,721.00

#### ESD Surface

TWB3624ES	36"W x 24"D x 26-38"H Adjustable Bench with ESD Laminate Surface	126	2,333.00
TWB3630ES	36"W x 30"D x 26-38"H Adjustable Bench with ESD Laminate Surface	130	2,650.00
TWB3636ES	36"W x 36"D x 26-38"H Adjustable Bench with ESD Laminate Surface	142	2,905.00

### 48"W STRAIGHT BENCH

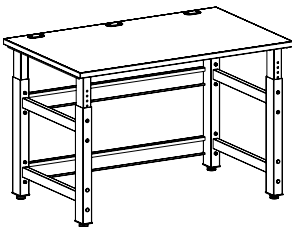

TWB4830H3

#### High Pressure Laminate (HPL) Surface

TWB4824H3	48"W x 24"D x 26-38"H Adjustable Bench with High Pressure Laminate Surface	131	2,202.00
TWB4830H3	48"W x 30"D x 26-38"H Adjustable Bench with High Pressure Laminate Surface	139	2,411.00
TWB4836H3	48"W x 36"D x 26-38"H Adjustable Bench with High Pressure Laminate Surface	150	2,510.00

#### Stainless Steel Surface

TWB4824SS	48"W x 24"D x 26-38"H Adjustable Bench with Stainless Steel Surface (No Grommets)	145	5,266.00
TWB4830SS	48"W x 30"D x 26-38"H Adjustable Bench with Stainless Steel Surface (No Grommets)	168	5,372.00
TWB4836SS	48"W x 36"D x 26-38"H Adjustable Bench with Stainless Steel Surface (No Grommets)	189	5,467.00

#### Butcher Block Surface

TWB4824BB	48"W x 24"D x 26-38"H Adjustable Bench with Butcher Block Surface	151	2,542.00
TWB4830BB	48"W x 30"D x 26-38"H Adjustable Bench with Butcher Block Surface	162	2,767.00
TWB4836BB	48"W x 36"D x 26-38"H Adjustable Bench with Butcher Block Surface	183	2,844.00

#### ESD Surface

TWB4824ES	48"W x 24"D x 26-38"H Adjustable Bench with ESD Laminate Surface	131	2,590.00
TWB4830ES	48"W x 30"D x 26-38"H Adjustable Bench with ESD Laminate Surface	139	2,948.00
TWB4836ES	48"W x 36"D x 26-38"H Adjustable Bench with ESD Laminate Surface	160	3,225.00



Item No.	Description	Weight (lbs.)	List Price
----------	-------------	---------------	------------

## 60"W STRAIGHT BENCH

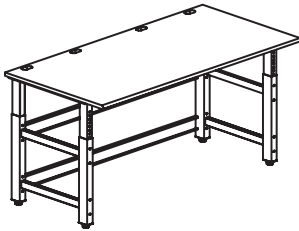

TWB6036H3

### High Pressure Laminate (HPL) Surface

TWB6024H3	60"W x 24"D x 26-38"H Adjustable Bench with High Pressure Laminate Surface	139	2,438.00
TWB6030H3	60"W x 30"D x 26-38"H Adjustable Bench with High Pressure Laminate Surface	155	2,489.00
TWB6036H3	60"W x 36"D x 26-38"H Adjustable Bench with High Pressure Laminate Surface	170	2,541.00

### Stainless Steel Surface

TWB6024SS	60"W x 24"D x 26-38"H Adjustable Bench with Stainless Steel Surface (No Grommets)	164	5,551.00
TWB6030SS	60"W x 30"D x 26-38"H Adjustable Bench with Stainless Steel Surface (No Grommets)	193	5,602.00
TWB6036SS	60"W x 36"D x 26-38"H Adjustable Bench with Stainless Steel Surface (No Grommets)	213	5,653.00

### Butcher Block Surface

TWB6024BB	60"W x 24"D x 26-38"H Adjustable Bench with Butcher Block Surface	158	3,067.00
TWB6030BB	60"W x 30"D x 26-38"H Adjustable Bench with Butcher Block Surface	187	3,566.00
TWB6036BB	60"W x 36"D x 26-38"H Adjustable Bench with Butcher Block Surface	207	3,607.00

### ESD Surface

TWB6024ES	60"W x 24"D x 26-38"H Adjustable Bench with ESD Laminate Surface	139	3,321.00
TWB6030ES	60"W x 30"D x 26-38"H Adjustable Bench with ESD Laminate Surface	155	3,764.00
TWB6036ES	60"W x 36"D x 26-38"H Adjustable Bench with ESD Laminate Surface	170	3,931.00

## 72"W STRAIGHT BENCH

### High Pressure Laminate (HPL) Surface

TWB7224H3	72"W x 24"D x 26-38"H Adjustable Bench with High Pressure Laminate Surface	170	2,467.00
TWB7230H3	72"W x 30"D x 26-38"H Adjustable Bench with High Pressure Laminate Surface	175	2,665.00
TWB7236H3	72"W x 36"D x 26-38"H Adjustable Bench with High Pressure Laminate Surface	185	2,819.00

### Stainless Steel Surface

TWB7224SS	72"W x 24"D x 26-38"H Adjustable Bench with Stainless Steel Surface (No Grommets)	201	5,801.00
TWB7230SS	72"W x 30"D x 26-38"H Adjustable Bench with Stainless Steel Surface (No Grommets)	221	5,995.00
TWB7236SS	72"W x 36"D x 26-38"H Adjustable Bench with Stainless Steel Surface (No Grommets)	242	6,153.00

### Butcher Block Surface

TWB7224BB	72"W x 24"D x 26-38"H Adjustable Bench with Butcher Block Surface	195	3,296.00
TWB7230BB	72"W x 30"D x 26-38"H Adjustable Bench with Butcher Block Surface	215	3,646.00
TWB7236BB	72"W x 36"D x 26-38"H Adjustable Bench with Butcher Block Surface	236	3,679.00

### ESD Surface

TWB7224ES	72"W x 24"D x 26-38"H Adjustable Bench with ESD Laminate Surface	170	3,803.00
TWB7230ES	72"W x 30"D x 26-38"H Adjustable Bench with ESD Laminate Surface	175	3,795.00
TWB7236ES	72"W x 36"D x 26-38"H Adjustable Bench with ESD Laminate Surface	185	3,959.00

Item No.	Description	Weight (lbs.)	List Price
<b>96"W STRAIGHT BENCH</b>			
<b>High Pressure Laminate (HPL) Surface</b>			
TWB9624H3	96"W x 24"D x 26-38"H Adjustable Bench with High Pressure Laminate Surface	198	3,843.00
TWB9630H3	96"W x 30"D x 26-38"H Adjustable Bench with High Pressure Laminate Surface	225	4,315.00
TWB9636H3	96"W x 36"D x 26-38"H Adjustable Bench with High Pressure Laminate Surface	245	4,716.00
<b>Stainless Steel Surface</b>			
TWB9624SS	96"W x 24"D x 26-38"H Adjustable Bench with Stainless Steel Surface (No Grommets)	242	6,238.00
TWB9630SS	96"W x 30"D x 26-38"H Adjustable Bench with Stainless Steel Surface (No Grommets)	276	6,344.00
TWB9636SS	96"W x 36"D x 26-38"H Adjustable Bench with Stainless Steel Surface (No Grommets)	306	6,439.00
<b>Butcher Block Surface</b>			
TWB9624BB	96"W x 24"D x 26-38"H Adjustable Bench with Butcher Block Surface	237	4,126.00
TWB9630BB	96"W x 30"D x 26-38"H Adjustable Bench with Butcher Block Surface	270	4,450.00
TWB9636BB	96"W x 36"D x 26-38"H Adjustable Bench with Butcher Block Surface	300	4,865.00
<b>ESD Surface</b>			
TWB9624ES	96"W x 24"D x 26-38"H Adjustable Bench with ESD Laminate Surface	198	4,510.00
TWB9624ES	96"W x 30"D x 26-38"H Adjustable Bench with ESD Laminate Surface	225	4,510.00
TWB9636ES	96"W x 36"D x 26-38"H Adjustable Bench with ESD Laminate Surface	245	5,266.00

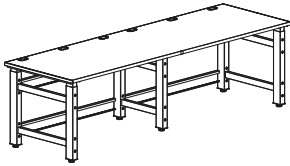

TWB9630H3

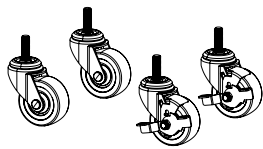

TWCASKIT4

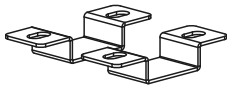

TWGANGKIT

## CASTER KITS & CONNECTORS

- Adding casters to a bench will add 3" to the overall bench height
- Each caster kit includes 2 locking casters which, lock the wheel. The remaining casters will not have a locking mechanism

TWCASKIT4	Caster Kit (4) For straight benches, electric height adjustable benches, and tables	7	275.00
TWGANGKIT	Ganging Kit (Two Brackets To Secure Side-By-Side Benches)	2	97.00

## CORNER BENCHES

Benches have 12" of travel range measuring 26" to 38" from the floor to the top of the work surface. Adjusts in 1" increments with threaded fasteners. Benches come standard with leveling glides; optional casters are available (Item TWCASKIT5 - Caster 5 pack) but will add 3" to overall bench height. Benches ship knocked down.

- Benches hold 1,000 lbs. evenly distributed
- Bench standard work surface options include:
  - HPL (High Pressure Laminate 1 1/8" thick) with 3mm PVC edge band on all sides
  - Butcher Block (1 3/4" thick) 1/8" radius on all sides
  - ESD (Electro-Static Discharge 1 1/8" thick) with ground terminus. ESD available in Gray laminate with Black edge banding only (Coordinating accessories available on pg. 65)
  - Stainless Steel not available on Corner Benches
- All work surfaces come standard with 1 3/4" x 3 1/4" grommet holes
- 24", 30" and 36"W squared corner benches do not have cutout on front - see below
- Additional colors and work surface materials are available (including phenolic) — upcharges, minimums and extended lead times may apply. Email [specials@safcoproducts.com](mailto:specials@safcoproducts.com) for quotation.

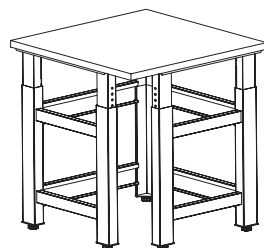
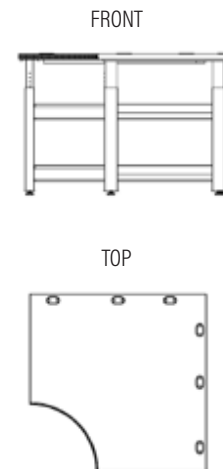
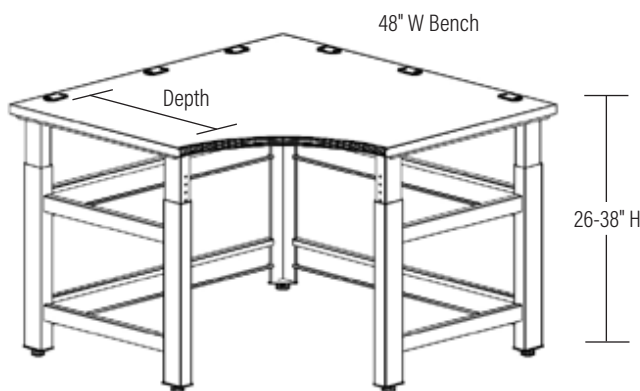

Squared 24", 30" and 36" Corner Benches

### HOW TO SPECIFY

1. Choose the bench work surface material	2. Choose the bench depth	3. Choose the bench width	4. Choose the bench finish	5. Add optional work surface accessories
HPL	24"	24" 48"	Powder coat paint color	Below work surface accessories (See options on pg. 40)
Butcher Block	30"	30" 60"	Work surface color if applicable	Above work surface organizer frame (See options on pg. 28)
ESD*	36"	36"	(See options on pg. 2)	

\*Includes grounding terminus; coordinating accessories available on pg. 65

Item No. Description Weight (lbs.) List Price

### 24"W CORNER BENCH

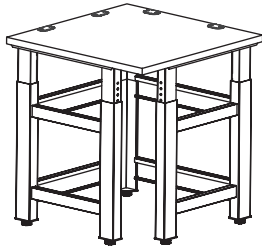

TWBC2424H3

#### High Pressure Laminate (HPL) Surface

TWBC2424H3	24"W x 24"D x 26-38"H Corner Adjustable Bench with High Pressure Laminate Surface	128	2,330.00
------------	---	-----	----------

#### Butcher Block Surface

TWBC2424BB	24"W x 24"D x 26-38"H Corner Adjustable Bench with Butcher Block Surface	237	2,739.00
------------	--	-----	----------

#### ESD Surface

TWBC2424ES	24"W x 24"D x 26-38"H Corner Adjustable Bench with ESD Laminate Surface	128	2,741.00
------------	---	-----	----------

### 30"W CORNER BENCH

#### High Pressure Laminate (HPL) Surface

TWBC3030H3	30"W x 30"D x 26-38"H Corner Adjustable Bench with High Pressure Laminate Surface	138	2,616.00
------------	---	-----	----------

#### Butcher Block Surface

TWBC3030BB	30"W x 30"D x 26-38"H Corner Adjustable Bench with Butcher Block Surface	149	2,922.00
------------	--	-----	----------

#### ESD Surface

TWBC3030ES	30"W x 30"D x 26-38"H Corner Adjustable Bench with ESD Laminate Surface	138	2,936.00
------------	---	-----	----------

### 36"W CORNER BENCH

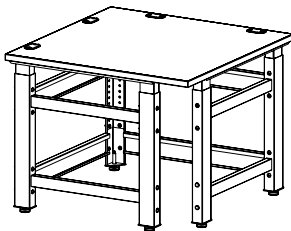

TWBC3636H3

#### High Pressure Laminate (HPL) Surface

TWBC3636H3	36"W x 36"D x 26-38"H Corner Adjustable Bench with High Pressure Laminate Surface	152	2,784.00
------------	---	-----	----------

#### Butcher Block Surface

TWBC3636BB	36"W x 36"D x 26-38"H Corner Adjustable Bench with Butcher Block Surface	164	3,144.00
------------	--	-----	----------

#### ESD Surface

TWBC3636ES	36"W x 36"D x 26-38"H Corner Adjustable Bench with ESD Laminate Surface	152	3,169.00
------------	---	-----	----------

### 48"W CORNER BENCH

#### High Pressure Laminate (HPL) Surface

TWBC4824H3	48"W x 24"D x 26-38"H Corner Adjustable Bench with High Pressure Laminate Surface	170	3,038.00
------------	---	-----	----------

TWBC4830H3	48"W x 30"D x 26-38"H Corner Adjustable Bench with High Pressure Laminate Surface	180	3,144.00
------------	---	-----	----------

TWBC4836H3	48"W x 36"D x 26-38"H Corner Adjustable Bench with High Pressure Laminate Surface	185	3,239.00
------------	---	-----	----------

#### Butcher Block Surface

TWBC4824BB	48"W x 24"D x 26-38"H Corner Adjustable Bench with Butcher Block Surface (2 Piece Top)	170	4,639.00
------------	--	-----	----------

TWBC4830BB	48"W x 30"D x 26-38"H Corner Adjustable Bench with Butcher Block Surface (2 Piece Top)	220	5,585.00
------------	--	-----	----------

TWBC4836BB	48"W x 36"D x 26-38"H Corner Adjustable Bench with Butcher Block Surface (2 Piece Top)	230	5,739.00
------------	--	-----	----------

#### ESD Surface

TWBC4824ES	48"W x 24"D x 26-38"H Corner Adjustable Bench with ESD Laminate Surface	170	3,611.00
------------	---	-----	----------

TWBC4830ES	48"W x 30"D x 26-38"H Corner Adjustable Bench with ESD Laminate Surface	180	3,679.00
------------	---	-----	----------

TWBC4836ES	48"W x 36"D x 26-38"H Corner Adjustable Bench with ESD Laminate Surface	185	3,912.00
------------	---	-----	----------

Item No. Description Weight (lbs.) List Price

**60"W CORNER BENCH**

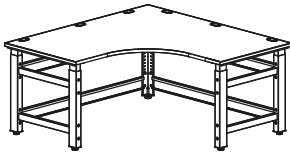

TWBC6030H3

**High Pressure Laminate (HPL) Surface**

TWBC6024H3	60"W x 24"D x 26-38"H Corner Adjustable Bench with High Pressure Laminate Surface	182	3,279.00
TWBC6030H3	60"W x 30"D x 26-38"H Corner Adjustable Bench with High Pressure Laminate Surface	192	3,448.00
TWBC6036H3	60"W x 36"D x 26-38"H Corner Adjustable Bench with High Pressure Laminate Surface	206	3,583.00

**Butcher Block Surface**

TWBC6024BB	60"W x 24"D x 26-38"H Corner Adjustable Bench with Butcher Block Surface (2 Piece Top)	222	4,700.00
TWBC6030BB	60"W x 30"D x 26-38"H Corner Adjustable Bench with Butcher Block Surface (2 Piece Top)	232	5,353.00
TWBC6036BB	60"W x 36"D x 26-38"H Corner Adjustable Bench with Butcher Block Surface (2 Piece Top)	242	5,616.00

**ESD Surface**

TWBC6024ES	60"W x 24"D x 26-38"H Corner Adjustable Bench with ESD Laminate Surface	182	3,972.00
TWBC6030ES	60"W x 30"D x 26-38"H Corner Adjustable Bench with ESD Laminate Surface	192	4,169.00
TWBC6036ES	60"W x 36"D x 26-38"H Corner Adjustable Bench with ESD Laminate Surface	206	4,274.00

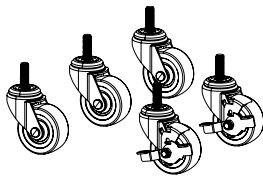

TWCASKIT5

**CASTER KITS & CONNECTORS**

- Adding casters to a bench will add 3" to the overall bench height
- Each caster kit includes 2 locking casters which, lock the wheel. The remaining casters will not have a locking mechanism

TWCASKIT5	Caster Kit (5) For Corner and L Benches	9	351.00
TWGANGKIT	Ganging Kit (Two Brackets To Secure Side-By-Side Benches)	2	97.00

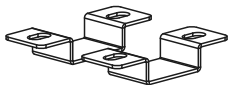

TWGANGKIT

## L-SHAPED BENCHES

Benches have 12" of travel range measuring 26" to 38" from the floor to the top of the work surface. Adjusts in 1" increments with threaded fasteners. Benches come standard with leveling glides; optional casters are available (Item TWCASKIT5 - Caster 5 pack) but will add 3" to overall bench height. Benches ship knocked down.

- All L-Shaped benches are 72"W x 48"
- Bench holds 1,000 lbs. evenly distributed
- Bench standard work surface options include:
  - HPL (High Pressure Laminate 1 1/8" thick) with 3mm PVC edge band on all sides
  - **Butcher Block** (1 3/4" thick) 1/8" radius on all sides
  - **ESD** (Electro-Static Discharge 1 1/8" thick) with ground terminus. ESD available in Gray laminate with Black edge banding only (Coordinating accessories available on pg. 65)
  - **Stainless Steel** not available on L Benches
- All work surfaces come standard with 1 3/4" x 3 1/4" grommet holes
- Right-handed and left-handed options available
- Additional colors and work surface materials are available (including phenolic) — upcharges, minimums and extended lead times may apply. Email [specials@safcoproducts.com](mailto:specials@safcoproducts.com) for quotation.

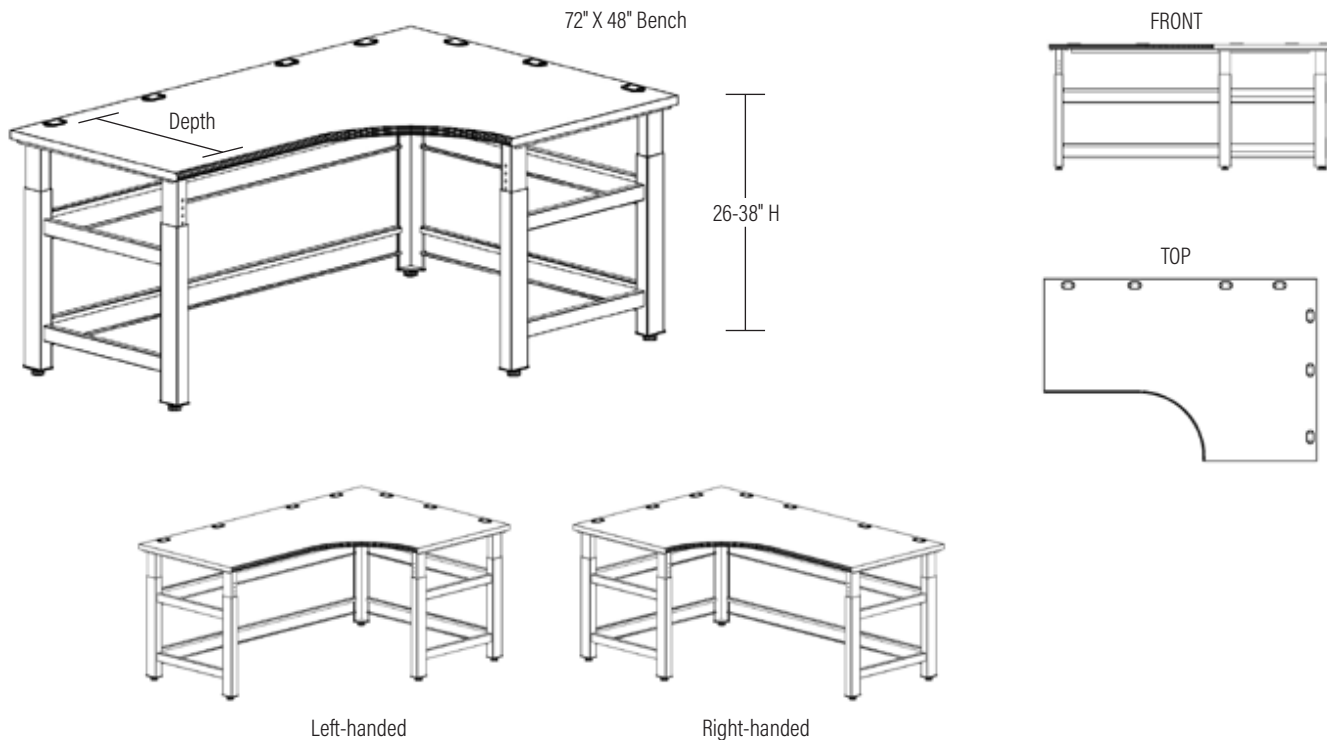

### HOW TO SPECIFY

1. Choose the bench work surface material	2. Choose the bench depth	3. Choose Right or Left handed	4. Choose the bench finish	5. Add optional work surface accessories
HPL	24"	Right-handed	Powder coat paint color	Below work surface accessories (See options on pg. 40)
Butcher Block	30"	Left-handed	Work surface color if applicable (See options on pg. 2)	Above work surface organizer frame (See options on pg. 28)
ESD*	36"			

\*Includes grounding terminus; coordinating accessories available on pg. 65

Item No.	Description	Weight (lbs.)	List Price
----------	-------------	---------------	------------

**L-SHAPED BENCH**

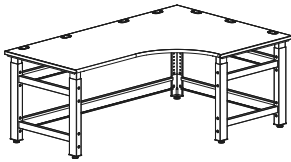

TWBL30LHH3

**High Pressure Laminate (HPL) Surface**

TWBL24LHH3	72"W x 48" x 24"D x 26-38"H Left-Hand, Adjustable L-Bench with High Pressure Laminate	161	3,715.00
TWBL24RHH3	72"W x 48" x 24"D x 26-38"H Right-Hand, Adjustable L-Bench with High Pressure Laminate	161	3,715.00
TWBL30LHH3	72"W x 48" x 30"D x 26-38"H Left-Hand, Adjustable L-Bench with High Pressure Laminate	167	3,790.00
TWBL30RHH3	72"W x 48" x 30"D x 26-38"H Right-Hand, Adjustable L-Bench with High Pressure Laminate	167	3,790.00
TWBL36LHH3	72"W x 48" x 36"D x 26-38"H Left-Hand, Adjustable L-Bench with High Pressure Laminate	189	3,884.00
TWBL36LHH3	72"W x 48" x 36"D x 26-38"H Right-Hand, Adjustable L-Bench with High Pressure Laminate	189	3,884.00

**Butcher Block Surface**

TWBL24LHBB	72"W x 48" x 24"D x 26-38"H Left-Hand, Adjustable L-Bench with Butcher Block (2 Piece Top)	225	6,267.00
TWBL24RHBB	72"W x 48" x 24"D x 26-38"H Right-Hand, Adjustable L-Bench with Butcher Block (2 Piece Top)	225	6,267.00
TWBL30LHBB	72"W x 48" x 30"D x 26-38"H Left-Hand, Adjustable L-Bench with Butcher Block (2 Piece Top)	250	6,542.00
TWBL30RHBB	72"W x 48" x 30"D x 26-38"H Right-Hand, Adjustable L-Bench with Butcher Block (2 Piece Top)	250	6,542.00
TWBL36LHBB	72"W x 48" x 36"D x 26-38"H Left-Hand, Adjustable L-Bench with Butcher Block (2 Piece Top)	270	6,804.00
TWBL36RHBB	72"W x 48" x 36"D x 26-38"H Right-Hand, Adjustable L-Bench with Butcher Block (2 Piece Top)	270	6,804.00

**ESD Surface**

TWBL24LHES	72"W x 48" x 24"D x 26-38"H Left-Hand, Adjustable L-Bench with ESD Laminate	161	4,292.00
TWBL24RHES	72"W x 48" x 24"D x 26-38"H Right-Hand, Adjustable L-Bench with ESD Laminate	161	4,292.00
TWBL30LHES	72"W x 48" x 30"D x 26-38"H Left-Hand, Adjustable L-Bench with ESD Laminate	167	4,326.00
TWBL30RHES	72"W x 48" x 30"D x 26-38"H Right-Hand, Adjustable L-Bench with ESD Laminate	167	4,326.00
TWBL36LHES	72"W x 48" x 36"D x 26-38"H Left-Hand, Adjustable L-Bench with ESD Laminate	189	4,608.00
TWBL36RHES	72"W x 48" x 36"D x 26-38"H Right-Hand, Adjustable L-Bench with ESD Laminate	189	4,608.00

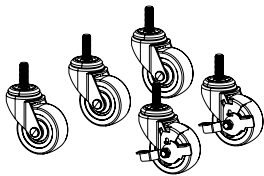

TWCASKIT5

**CASTER KITS & CONNECTORS**

- Adding casters to a bench will add 3" to the overall bench height
- Each caster kit includes 2 locking casters which, lock the wheel. The remaining casters will not have a locking mechanism

TWCASKIT5	Caster Kit (5) For Corner and L Benches	9	351.00
TWGANGKIT	Ganging Kit (Two Brackets To Secure Side-By-Side Benches)	2	97.00

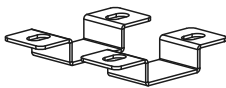

TWGANGKIT

## ELECTRIC HEIGHT-ADJUSTABLE BENCHES

Benches have 25" of travel range measuring 25" to 50" from the floor to the top of the work surface. Benches come standard with leveling glides; optional casters are available (Item TWCASKIT4 - Caster 4 pack) but will add 3" to overall bench height. Benches ship knocked down.

- Bench holds 1,000 lbs. evenly distributed
- Bench standard work surface options include:
  - HPL (High Pressure Laminate 1 1/8" thick) with 3mm PVC edge band on all sides
  - Stainless Steel work-surface is 1 5/8" thick 16GA, type 304, #4 finish with wrapped and welded corners and a particle board core
  - Butcher Block (1 3/4" thick) 1/8" radius on all sides
  - ESD (Electro-Static Discharge 1 1/8" thick) with ground terminus. ESD available in Gray laminate with Black edge banding only (coordinating accessories available on pg. 65)
- HPL, Butcher Block, and ESD work surfaces come standard with 1 3/4" x 3 1/4" grommet holes (Stainless Steel Benches are NOT available with grommet holes)
- All benches are 30" D
- Additional colors and work surface materials are available (including phenolic) — upcharges, minimums and extended lead times may apply. Email [specials@safcoproducts.com](mailto:specials@safcoproducts.com) for quotation.

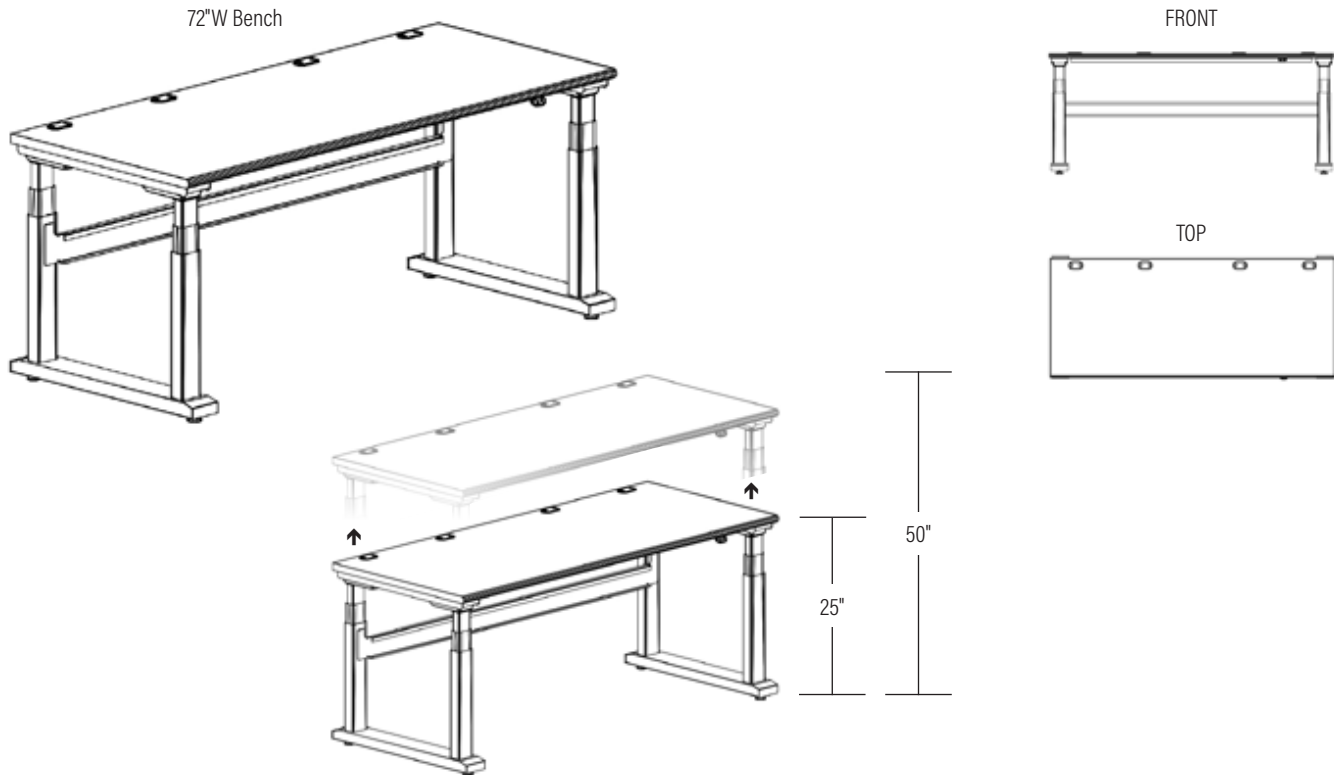

### HOW TO SPECIFY

1. Choose the bench work surface material	2. Choose the bench width	3. Choose the bench finish	4. Add optional work surface accessories
HPL	48"	Powder coat paint color	Above work surface organizer frame (See options on pg. 28)
Stainless Steel	60"	Work surface color if applicable	
Butcher Block	72"	(See options on pg. 2)	
ESD*			

\*Includes grounding terminus; coordinating accessories available on pg. 65.



Item No.	Description	Weight (lbs.)	List Price
----------	-------------	---------------	------------

**ELECTRIC HEIGHT ADJUSTABLE BENCHES**

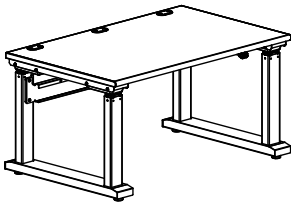

TWBHA60H3

**High Pressure Laminate (HPL) Surface**

TWBHA48H3	48"W x 30"D x 25-50"H Height Adjustable Bench with High Pressure Laminate Surface	165	7,397.00
TWBHA60H3	60"W x 30"D x 25-50"H Height Adjustable Bench with High Pressure Laminate Surface	185	7,577.00
TWBHA72H3	72"W x 30"D x 25-50"H Height Adjustable Bench with High Pressure Laminate Surface	205	7,649.00

**Stainless Steel Surface**

TWBHA48SS	48"W x 30"D x 25-50"H Height Adjustable Bench with Stainless Steel Surface (No Grommets)	200	9,882.00
TWBHA60SS	60"W x 30"D x 25-50"H Height Adjustable Bench with Stainless Steel Surface (No Grommets)	214	10,290.00
TWBHA72SS	72"W x 30"D x 25-50"H Height Adjustable Bench with Stainless Steel Surface (No Grommets)	238	10,855.00

**Butcher Block Surface**

TWBHA48BB	48"W x 30"D x 25-50"H Height Adjustable Bench with Butcher Block Surface	184	7,747.00
TWBHA60BB	60"W x 30"D x 25-50"H Height Adjustable Bench with Butcher Block Surface	208	8,534.00
TWBHA72BB	72"W x 30"D x 25-50"H Height Adjustable Bench with Butcher Block Surface	232	8,602.00

**ESD Surface**

TWBHA48ES	48"W x 30"D x 25-50"H Height Adjustable Bench with ESD Laminate Surface	165	7,932.00
TWBHA60ES	60"W x 30"D x 25-50"H Height Adjustable Bench with ESD Laminate Surface	185	8,896.00
TWBHA72ES	72"W x 30"D x 25-50"H Height Adjustable Bench with ESD Laminate Surface	205	8,971.00

**CASTER KITS & CONNECTORS**

- Adding casters to a bench will add 3" to the overall bench height
- Each caster kit includes 2 locking casters which, lock the wheel. The remaining casters will not have a locking mechanism

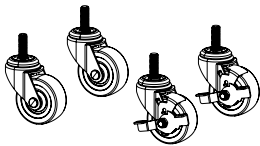

TWCASKIT4

TWCASKIT4	Caster Kit (4) For straight benches, electric height adjustable benches, and tables	7	275.00
TWGANGKIT	Ganging Kit (Two Brackets To Secure Side-By-Side Benches)	2	97.00

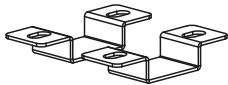

TWGANGKIT

# TABLES

Table has 12" of travel range measuring 26" to 38" from the floor to the top of the work surface. Adjusts in 1" increments with threaded fasteners. Tables comes standard with leveling glides; optional casters are available (Item TWCASKIT4 - Caster 4 pack) but will add 3" to overall bench height. Tables ship knocked down.

- Tables holds 1,000 lbs. evenly distributed
- Table standard work surface options include:
  - **HPL** (High Pressure Laminate 1 1/8" thick) with 3mm PVC edge band on all sides
  - **Stainless Steel** work-surface is 1 5/8" thick 16GA, type 304, #4 finish with wrapped and welded corners and a particle board core
  - **Butcher Block** (1 3/4" thick) 1/8" radius on all sides
  - **ESD** (Electro-Static Discharge 1 1/8" thick) with ground terminus.
- Attach multiple table work surfaces together using connector kit (Item TWGANGKIT)
- Full base shelf under the work surface is required
- Work surface does not include grommet holes
- Tables are not compatible with organizer frames and under work surface accessories
- Additional colors and work surface materials are available (including phenolic) — upcharges, minimums and extended lead times may apply. Email [specials@safcoproducts.com](mailto:specials@safcoproducts.com) for quotation.

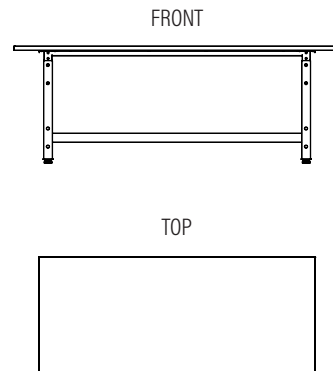
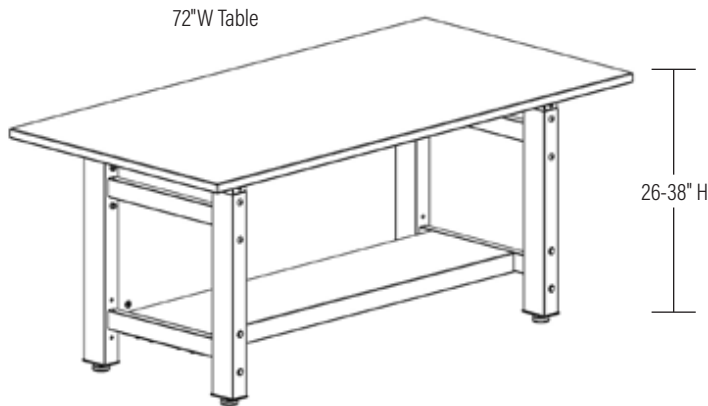

## HOW TO SPECIFY

1. Choose the table work surface material	2. Choose the table depth	3. Choose the table width	5. Choose the bench finish
HPL	30"	48"	Powder coat paint color
Stainless Steel	36"	60"	Work surface color if applicable
Butcher Block		72"	(See options on pg. 2)
ESD*			

\*Includes grounding terminus; coordinating accessories available on pg. 65.

Item No.	Description	Weight (lbs.)	List Price
<b>48"W RECTANGLE TABLE</b>			
<b>High Pressure Laminate (HPL) Surface</b>			
TWT4830H3	48"W x 30"D x 26-38"H Rectangular Table with High Pressure Laminate Surface	139	2,363.00
TWT4836H3	48"W x 36"D x 26-38"H Rectangular Table with High Pressure Laminate Surface	150	2,462.00
<b>Stainless Steel Surface</b>			
TWT4830SS	48"W x 30"D x 26-38"H Rectangular Table with Stainless Steel Surface	168	5,266.00
TWT4836SS	48"W x 36"D x 26-38"H Rectangular Table with Stainless Steel Surface	191	5,365.00
<b>Butcher Block Surface</b>			
TWT4830BB	48"W x 30"D x 26-38"H Rectangular Table with Butcher Block Surface	162	2,892.00
TWT4836BB	48"W x 36"D x 26-38"H Rectangular Table with Butcher Block Surface	183	2,991.00
<b>ESD Surface</b>			
TWT4830ES	48"W x 30"D x 26-38"H Rectangular Table with ESD Surface	139	2,898.00
TWT4836ES	48"W x 36"D x 26-38"H Rectangular Table with ESD Surface	150	3,192.00
<b>60"W RECTANGLE TABLE</b>			
<b>High Pressure Laminate (HPL) Surface</b>			
TWT6030H3	60"W x 30"D x 26-38"H Rectangular Table with High Pressure Laminate Surface	155	2,436.00
TWT6036H3	60"W x 36"D x 26-38"H Rectangular Table with High Pressure Laminate Surface	170	2,542.00
<b>Stainless Steel Surface</b>			
TWT6030SS	60"W x 30"D x 26-38"H Rectangular Table with Stainless Steel Surface	193	5,551.00
TWT6036SS	60"W x 36"D x 26-38"H Rectangular Table with Stainless Steel Surface	215	5,657.00
<b>Butcher Block Surface</b>			
TWT6030BB	60"W x 30"D x 26-38"H Rectangular Table with Butcher Block Surface	187	3,519.00
TWT6036BB	60"W x 36"D x 26-38"H Rectangular Table with Butcher Block Surface	207	3,675.00
<b>ESD Surface</b>			
TWT6030ES	60"W x 30"D x 26-38"H Rectangular Table with ESD Surface	155	3,830.00
TWT6036ES	60"W x 36"D x 26-38"H Rectangular Table with ESD Surface	170	3,936.00
<b>72"W RECTANGLE TABLE</b>			
<b>High Pressure Laminate (HPL) Surface</b>			
TWT7230H3	72"W x 30"D x 26-38"H Rectangular Table with High Pressure Laminate Surface	175	2,616.00
TWT7236H3	72"W x 36"D x 26-38"H Rectangular Table with High Pressure Laminate Surface	185	2,768.00
<b>Stainless Steel Surface</b>			
TWT7230SS	72"W x 30"D x 26-38"H Rectangular Table with Stainless Steel Surface	221	5,801.00
TWT7236SS	72"W x 36"D x 26-38"H Rectangular Table with Stainless Steel Surface	245	5,953.00
<b>Butcher Block Surface</b>			
TWT7230BB	72"W x 30"D x 26-38"H Rectangular Table with Butcher Block Surface	215	3,596.00
TWT7236BB	72"W x 36"D x 26-38"H Rectangular Table with Butcher Block Surface	236	3,791.00
<b>ESD Surface</b>			
TWT7230ES	72"W x 30"D x 26-38"H Rectangular Table with ESD Surface	175	3,863.00
TWT7236ES	72"W x 36"D x 26-38"H Rectangular Table with ESD Surface	185	3,988.00

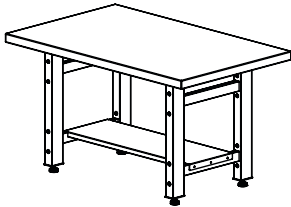

TWT4830H3

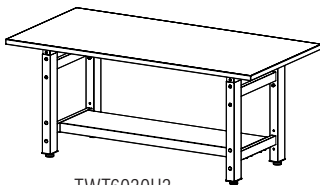

TWT6030H3

# STRAIGHT ORGANIZER FRAMES

Open frame design provides above work surface support for hanging accessories. Fixed height organizer frame mechanically fastens to the TechWorks Bench work surface and height adjusts with the bench. Frames allow for vertical adjustment of accessories in 1" increments. Frames ship knocked down.

- 14-Gauge cold rolled steel construction, organizer frames hold up to 400 lbs. evenly distributed
- Designed for horizontal and vertical integrated cable management between the frame uprights
- For back-to-back benching applications:
  - Add item TWSHUFKIT if using one shared organizer frame back-to-back (straight benches only, not compatible with corner or L benches)
  - Add item TWUFBRACE if using two separate organizer frames back-to-back (compatible with straight, corner and L benches)
- To add optional organizer frame accessories, see pg. 34

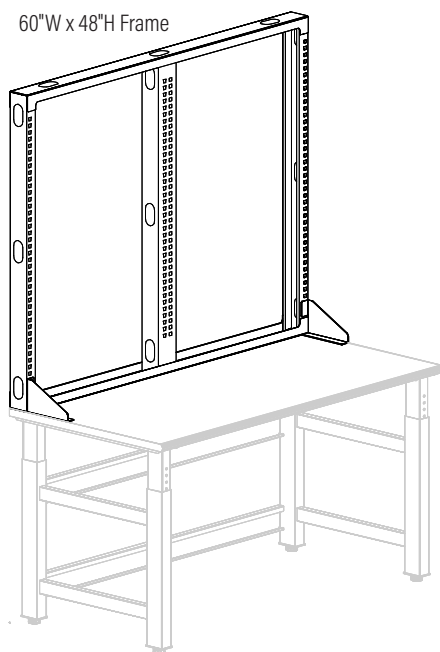

60"W x 48"H Frame

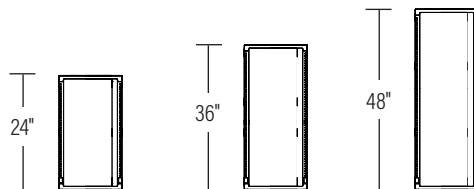
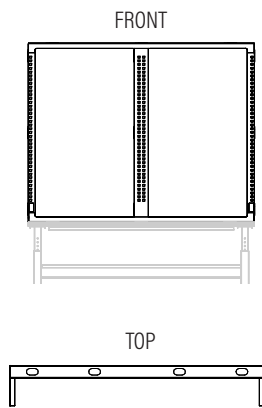

24" FRAME ASSEMBLY  
1-24" Section



30" FRAME ASSEMBLY  
1-30" Section

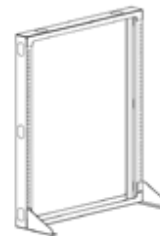

36" FRAME ASSEMBLY  
1-36" Section

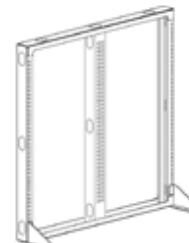

48" FRAME ASSEMBLY  
2-24" Sections

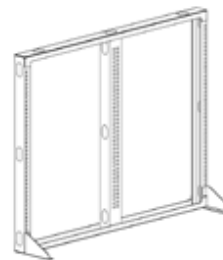

60" FRAME ASSEMBLY  
2-30" Sections

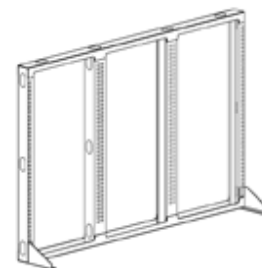

72" FRAME ASSEMBLY  
3-24" Sections

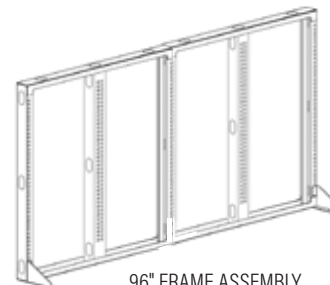

96" FRAME ASSEMBLY  
2-48" Sections

## HOW TO SPECIFY

1. Add organizer frames to equal bench width	2. Choose the organizer frame height	3. Choose the organizer frame finish
24" Bench use 1-24" Frame Section	24"	Powder coat paint color (See options on pg. 2)
30" Bench use 1-30" Frame Section	36"	
36" Bench use 1-36" Frame Section	48"	
48" Bench use 2-24" Frame Sections		
60" Bench use 2-30" Frame Sections		
72" Bench use 3-24" Frame Sections		
96" Bench use 2-48" Frame Sections		

Item No.	Description	Weight (lbs.)	List Price
----------	-------------	---------------	------------

**STRAIGHT ORGANIZER FRAMES**

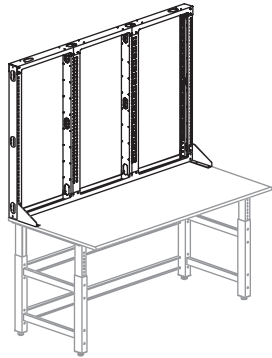

TWUF7248

<b>24"W Frame</b>			
TWUF2424	24"W x 24"H, Upper Organizer Frame	20	745.00
TWUF2436	24"W x 36"H, Upper Organizer Frame	23	779.00
TWUF2448	24"W x 48"H, Upper Organizer Frame	25	809.00
<b>30"W Frame</b>			
TWUF3024	30"W x 24"H, Upper Organizer Frame	22	779.00
TWUF3036	30"W x 36"H, Upper Organizer Frame	24	827.00
TWUF3048	30"W x 48"H, Upper Organizer Frame	27	896.00
<b>36"W Frame</b>			
TWUF3624	36"W x 24"H, Upper Organizer Frame	24	814.00
TWUF3636	36"W x 36"H, Upper Organizer Frame	26	898.00
TWUF3648	36"W x 48"H, Upper Organizer Frame	29	969.00
<b>48"W Frame</b>			
TWUF4824	48"W x 24"H, Upper Organizer Frame*	31	1,035.00
TWUF4836	48"W x 36"H, Upper Organizer Frame*	35	1,118.00
TWUF4848	48"W x 48"H, Upper Organizer Frame*	39	1,269.00
*Order two frames for 96"W bench			
<b>60"W Frame</b>			
TWUF6024	60"W x 24"H, Upper Organizer Frame	42	1,141.00
TWUF6036	60"W x 36"H, Upper Organizer Frame	45	1,260.00
TWUF6048	60"W x 48"H, Upper Organizer Frame	51	1,356.00
<b>72"W Frame</b>			
TWUF7224	72"W x 24"H, Upper Organizer Frame	53	1,260.00
TWUF7236	72"W x 36"H, Upper Organizer Frame	59	1,373.00
TWUF7248	72"W x 48"H, Upper Organizer Frame	67	1,487.00

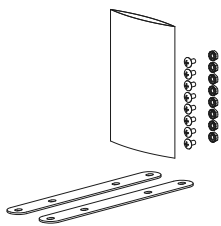

TWUFBRACE

**FRAME HARDWARE KITS**

TWSHUFKIT	Back-to-Back Shared Upper Frame Hardware Kit	14	195.00
TWUFBRACE	Back-to-Back Organizer Frame Brace (Used with 2 organizer frames)	7	104.00

# CORNER ORGANIZER FRAMES

Open frame design provides above work surface support for hanging accessories. Fixed height organizer frame mechanically fastens to the TechWorks Bench work surface and height adjusts with the bench. Frames allow for vertical adjustment of accessories in 1" increments. Frames ship knocked down.

- 14-Gauge cold rolled steel construction, organizer frames hold up to 400 lbs. evenly distributed
- Designed for horizontal and vertical integrated cable management between the frame uprights
  - Inner grommets of a corner frames do not line-up with grommets of straight Techworks Benches; specify corner benches for correct alignment of grommets
  - Inner frame sections of corner units are only compatible with corner accessories
  - Shared organizer frame support brackets (Item TWSHUFKIT) are not compatible with corner frame applications
- To add optional organizer frame accessories, see pg. 38

Corner Frame

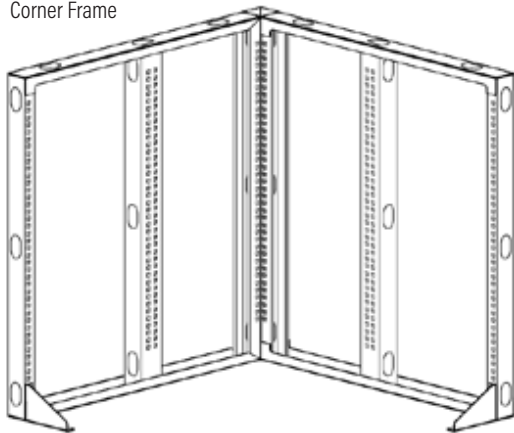

FRONT/SIDE

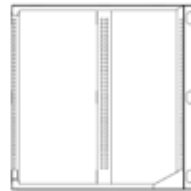

TOP

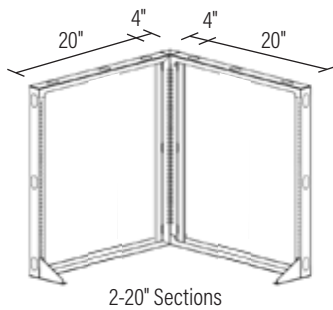
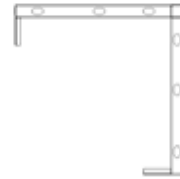

24" CORNER FRAME

2-20" Sections

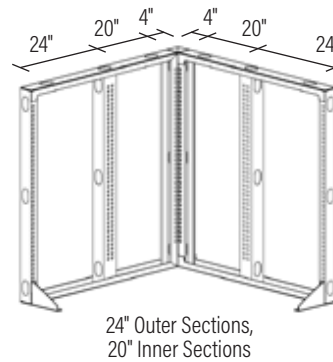

48" CORNER FRAME

24" Outer Sections,  
20" Inner Sections

## HOW TO SPECIFY

1. Add organizer frames to equal bench width	2. Choose the organizer frame height	3. Choose the organizer frame finish
24" Bench use 24" Corner Frame (2-20" Frame Sections)	24"	Powder coat paint color (See options on pg. 2)
30" Bench use 30" Corner Frame (2-26" Frame Sections)	36"	
36" Bench use 36" Corner Frame (2-32" Frame Sections)	48"	
48" Bench use 48" Corner Frame (2-44" Frame Sections) • includes 24" outer section and a 20" inner section		
60" Bench use 60" Corner Frame (2-56" Frame Sections) • includes 30"W outer section and 26" inner section		
72" Bench use 72" Corner Frame (2-68" Frame Sections) • includes 2-24"W outer sections and 1-20" section		

Item No. Description Weight (lbs.) List Price

**CORNER ORGANIZER FRAMES**

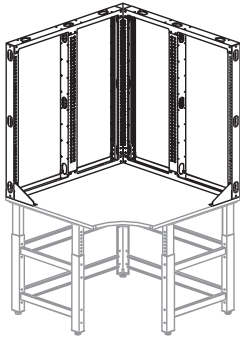

TWUCF4848

**24"W Frame**

TWUCF2424	24"W x 24"H, Upper Corner Organizer Frame*	55	1,240.00
TWUCF2436	24"W x 36"H, Upper Corner Organizer Frame*	59	1,306.00
TWUCF2448	24"W x 48"H, Upper Corner Organizer Frame*	69	1,369.00

\*Consists of one 20"W frame section, each side. (Inside dimensions)

**30"W Frame**

TWUCF3024	30"W x 24"H, Upper Corner Organizer Frame*	58	1,291.00
TWUCF3036	30"W x 36"H, Upper Corner Organizer Frame*	62	1,355.00
TWUCF3048	30"W x 48"H, Upper Corner Organizer Frame*	73	1,435.00

\*Consists of one 26"W frame section, each side. (Inside dimensions)

**36"W Frame**

TWUCF3624	36"W x 24"H, Upper Corner Frame*	60	1,339.00
TWUCF3636	36"W x 36"H, Upper Corner Frame*	67	1,421.00
TWUCF3648	36"W x 48"H, Upper Corner Frame*	75	1,498.00

\*Consists of one 32"W frame section, each side. (Inside dimensions)

**48"W Frame**

TWUCF4824	48"W x 24"H, Upper Corner Organizer Frame*	65	1,872.00
TWUCF4836	48"W x 36"H, Upper Corner Organizer Frame*	72	1,948.00
TWUCF4848	48"W x 48"H, Upper Corner Organizer Frame*	80	2,132.00

\*Consists of one 24"W outer frame section and one 20"W inner frame section, each side.

**60"W Frame**

TWUCF6024	60"W x 24"H, Upper Corner Organizer Frame*	68	1,953.00
TWUCF6036	60"W x 36"H, Upper Corner Organizer Frame*	74	2,069.00
TWUCF6048	60"W x 48"H, Upper Corner Organizer Frame*	80	2,196.00

\*Consists of one 30"W outer frame section and one 26"W inner frame section, each side.

**FRAME HARDWARE KITS**

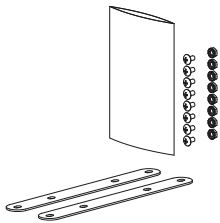

TWUFBRACE

TWUFBRACE	Back-to-Back Organizer Frame Brace (Used with 2 organizer frames)	7	104.00
-----------	---	---	--------

# L-SHAPED ORGANIZER FRAMES

Open frame design provides above work surface support for hanging accessories. Fixed height organizer frame mechanically fastens to the TechWorks Bench work surface and height adjusts with the bench. Frames allow for vertical adjustment of accessories in 1" increments. Frames ship knocked down.

- 14-Gauge cold rolled steel construction, organizer frames hold up to 400 lbs. evenly distributed
- Designed for horizontal and vertical integrated cable management between the frame uprights
  - Inner frame sections of L-Shaped units are only compatible with corner accessories (See organizer frame accessories pg. 38) for more details
  - Inner grommets of corner frames do not line-up with grommets of straight Techworks Benches; specify L-Shape frames with L-Shaped benches for correct alignment of grommets
  - Shared organizer frame support brackets (Item TWSHUFKIT) are not compatible with L-Shaped frame applications
- To add optional organizer frame accessories, see pg. 34

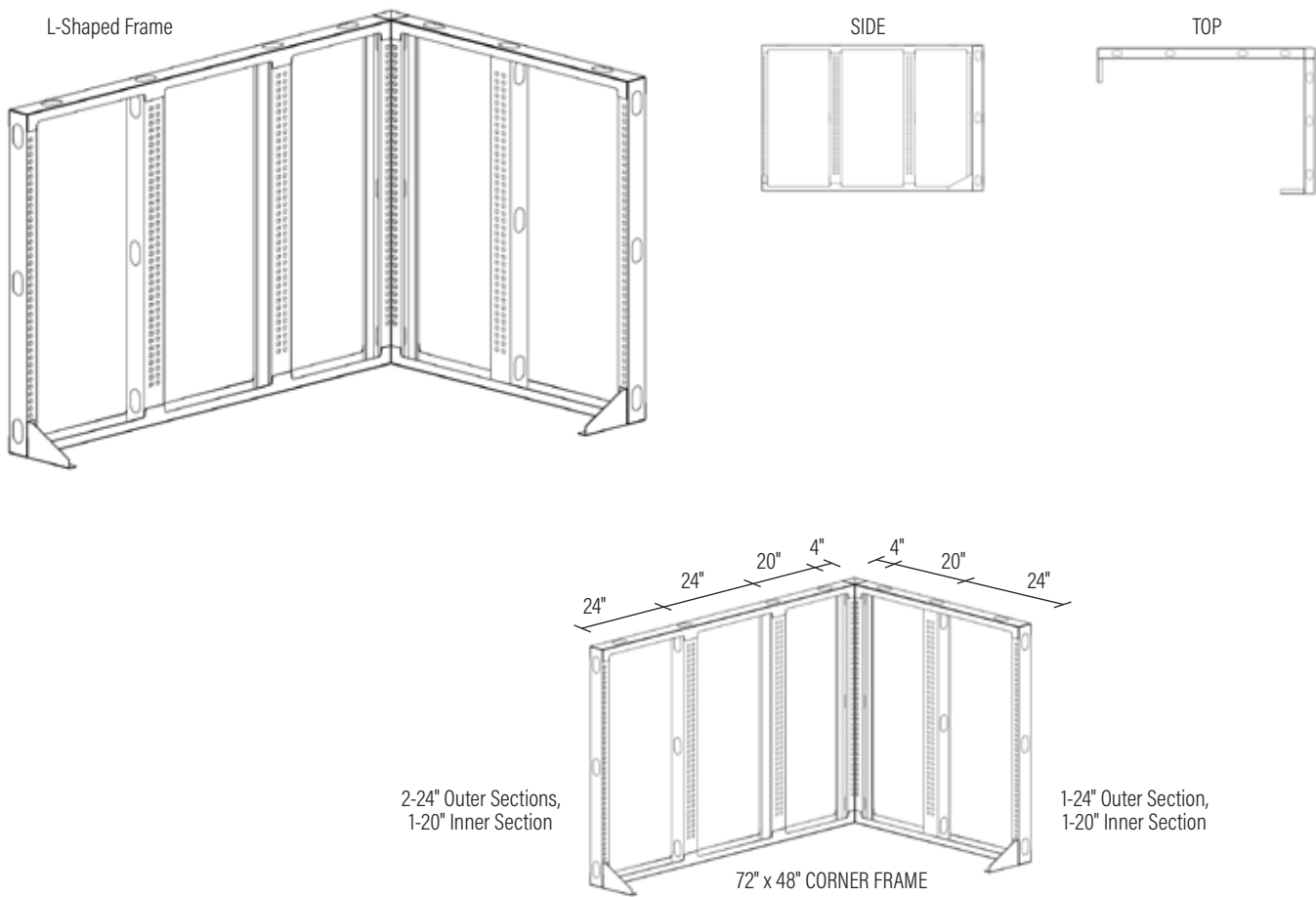

## HOW TO SPECIFY

1. Add organizer frames to equal bench width	2. Choose the organizer frame height	3. Choose the organizer frame finish
72" Bench use 72" L Frame (72" x 48"), consisting of 1-68" Frame Assembly (2-24" outer sections and 1-20" inner section for 72" side), and 1-44" Frame Assembly (1-24" outer section and 1-20" inner section for 48" side)	24" 36" 48"	Powder coat paint color (See options on pg. 2)



Item No.	Description	Weight (lbs.)	List Price
----------	-------------	---------------	------------

**L-SHAPED ORGANIZER FRAMES**

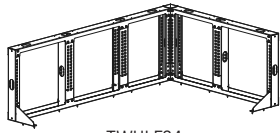

TWULF24

**72"W x 48"D Frame**

TWULF24	72"W x 48"D x 24"H, Upper "L" Organizer Frame*	64	2,027.00
TWULF36	72"W x 48"D x 36"H, Upper "L" Organizer Frame*	70	2,138.00
TWULF48	72"W x 48"D x 48"H, Upper "L" Organizer Frame*	76	2,294.00

\*Consists of two 24"W outer frame sections and one 20"W inner frame section for the 72"W side. 48"W side consists of one 24"W outer frame section and one 20"W inner frame section.

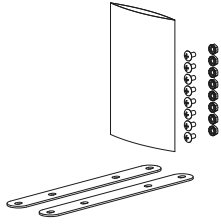

TWUFBRACE

**FRAME HARDWARE KITS**

TWUFBRACE	Back-to-Back Organizer Frame Brace (Used with 2 organizer frames)	7	104.00
-----------	---	---	--------

## FIXED CANTILEVERED - STRAIGHT RECTANGULAR SHELVES

Fixed Cantilevered Shelves provide general storage. Fixed Cantilevered Shelves can be used with straight organizer frames, corner organizer frames and L-shaped organizer frames "outer" sections only (Not compatible with corner organizer frames and L-shaped organizer frames "inner" sections). For inside corner frames, see corner shelves on pg. 38.

- Shelf weight capacity is 200 lbs.
- Shelves are adjustable on 1" increments
- Shelves install and can be relocated for easy adaptability

Shelves shown on organizer frame

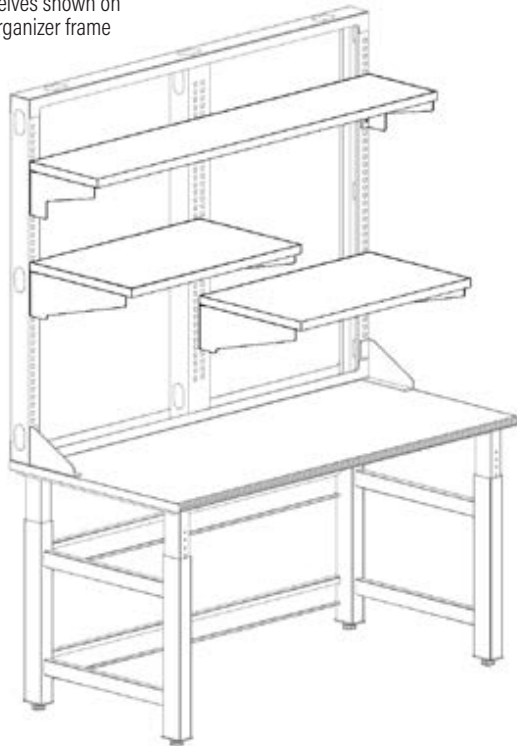

FRONT

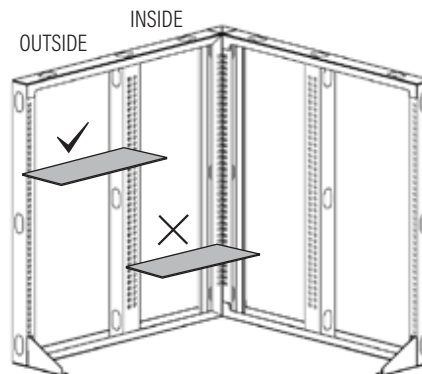

Placement of straight shelves on a corner frame  
(Outside sections only)

### HOW TO SPECIFY

1. Choose the shelf material	2. Choose the shelf width that matches your organizer frame	3. Choose the shelf depth	4. Choose the shelf finish
HPL	24"    48"	12"	Shelf laminate color (if applicable)
ESD*	30"    60"	18"	Shelf edge band color
	36"    72"		Powder coat paint color (See options on pg. 2)

\*Includes grounding terminus; coordinating accessories available on pg. 65

Item No.	Description	Weight (lbs.)	List Price
----------	-------------	---------------	------------

## 12"D FIXED CANTILEVERED SHELVES

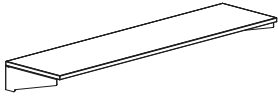

### 24"W Shelves

TWFS2412H3	24"W x 12"D Fixed Shelf with High Pressure Laminate Surface	22	709.00
TWFS2412ES	24"W x 12"D Fixed Shelf with ESD Laminate Surface	22	799.00

### 30"W Shelves

TWFS3012H3	30"W x 12"D Fixed Shelf with High Pressure Laminate Surface	28	739.00
TWFS3012ES	30"W x 12"D Fixed Shelf with ESD Laminate Surface	28	825.00

### 36"W Shelves

TWFS3612H3	36"W x 12"D Fixed Shelf with High Pressure Laminate Surface	33	748.00
TWFS3612ES	36"W x 12"D Fixed Shelf with ESD Laminate Surface	33	853.00

### 48"W Shelves

TWFS4812H3	48"W x 12"D Fixed Shelf with High Pressure Laminate Surface	34	786.00
TWFS4812ES	48"W x 12"D Fixed Shelf with ESD Laminate Surface	34	914.00

### 60"W Shelves

TWFS6012H3	60"W x 12"D Fixed Shelf with High Pressure Laminate Surface	41	878.00
TWFS6012ES	60"W x 12"D Fixed Shelf with ESD Laminate Surface	41	1,044.00

### 72"W Shelves

TWFS7212H3	72"W x 12"D Fixed Shelf with High Pressure Laminate Surface	47	965.00
TWFS7212ES	72"W x 12"D Fixed Shelf with ESD Laminate Surface	47	1,104.00

## 18"D FIXED CANTILEVERED SHELVES

### 24"W Shelves

TWFS2418H3	24"W x 18"D Fixed Shelf with High Pressure Laminate Surface	29	952.00
TWFS2418ES	24"W x 18"D Fixed Shelf with ESD Laminate Surface	29	1,066.00

### 30"W Shelves

TWFS3018H3	30"W x 18"D Fixed Shelf with High Pressure Laminate Surface	37	983.00
TWFS3018ES	30"W x 18"D Fixed Shelf with ESD Laminate Surface	37	1,098.00

### 36"W Shelves

TWFS3618H3	36"W x 18"D Fixed Shelf with High Pressure Laminate Surface	44	1,018.00
TWFS3618ES	36"W x 18"D Fixed Shelf with ESD Laminate Surface	44	1,160.00

### 48"W Shelves

TWFS4818H3	48"W x 18"D Fixed Shelf with High Pressure Laminate Surface	45	1,049.00
TWFS4818ES	48"W x 18"D Fixed Shelf with ESD Laminate Surface	45	1,258.00

### 60"W Shelves

TWFS6018H3	60"W x 18"D Fixed Shelf with High Pressure Laminate Surface	55	1,167.00
TWFS6018ES	60"W x 18"D Fixed Shelf with ESD Laminate Surface	55	1,514.00

### 72"W Shelves

TWFS7218H3	72"W x 18"D Fixed Shelf with High Pressure Laminate Surface	61	1,283.00
TWFS7218ES	72"W x 18"D Fixed Shelf with ESD Laminate Surface	61	1,619.00

# TILTED CANTILEVERED - STRAIGHT RECTANGULAR SHELVES

Tilt Cantilevered Shelves provide general storage. Tilt shelves have full-length raised safety edge to prevent forward slippage of stored equipment. Tilt shelves can be positioned at 0°, 5°, or 10°. Tilt Cantilevered Shelves can be used with straight organizer frames, corner organizer frames and L-shaped organizer frames "outer" sections only (Not compatible with corner organizer frames and L-shaped organizer frames "inner" sections).

- Shelf weight capacity is 200 lbs.
- Shelves are adjustable on 1" increments
- Shelves install and can be relocated for easy adaptability

Shelves shown on organizer frame

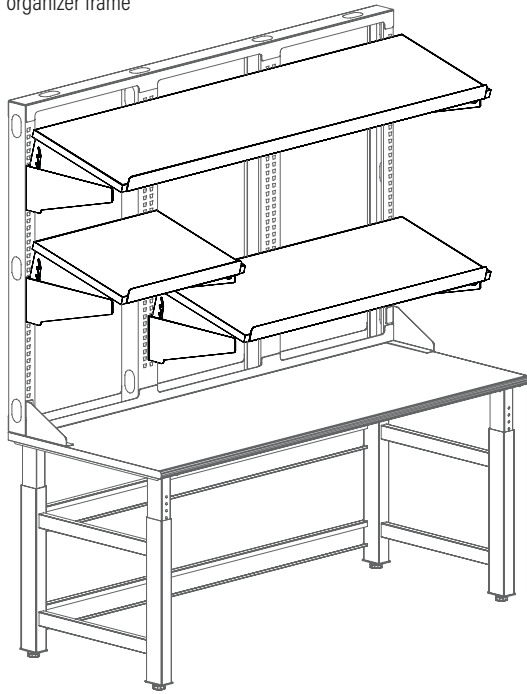

FRONT

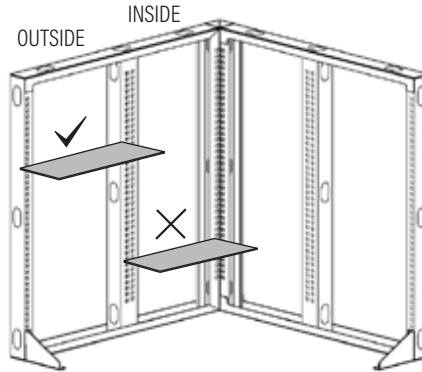
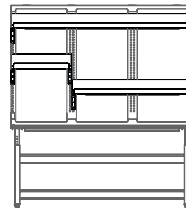

Placement of straight shelves on a corner frame (Outside sections only)

## HOW TO SPECIFY

1. Choose the shelf material	2. Choose the shelf width that matches your organizer frame	3. Choose the shelf depth	4. Choose the shelf finish
HPL	24"    48"	18"	Shelf laminate color (if applicable)
ESD*	30"    60"		Shelf edge band color
	36"    72"		Powder coat paint color
			(See options on pg. 2)

\*Includes grounding terminus; coordinating accessories available on pg. 65

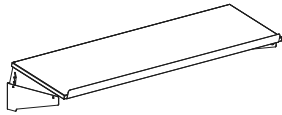

Item No.	Description	Weight (lbs.)	List Price
<b>18"D TILTED CANTILEVERED SHELVES</b>			
<b>24"W Shelves</b>			
TWTS2418H3	24"W x 18"D Tilted Shelf with High Pressure Laminate Surface		1,113.00
TWTS2418ES	24"W x 18"D Tilted Shelf with ESD Laminate Surface		1,230.00
<b>30"W Shelves</b>			
TWTS3018H3	30"W x 18"D Tilted Shelf with High Pressure Laminate Surface		1,179.00
TWTS3018ES	30"W x 18"D Tilted Shelf with ESD Laminate Surface		1,301.00
<b>36"W Shelves</b>			
TWTS3618H3	36"W x 18"D Tilted Shelf with High Pressure Laminate Surface		1,230.00
TWTS3618ES	36"W x 18"D Tilted Shelf with ESD Laminate Surface		1,385.00
<b>48"W Shelves</b>			
TWTS4818H3	48"W x 18"D Tilted Shelf with High Pressure Laminate Surface		1,283.00
TWTS4818ES	48"W x 18"D Tilted Shelf with ESD Laminate Surface		1,471.00
<b>60"W Shelves</b>			
TWTS6018H3	60"W x 18"D Tilted Shelf with High Pressure Laminate Surface		1,392.00
TWTS6018ES	60"W x 18"D Tilted Shelf with ESD Laminate Surface		1,590.00
<b>72"W Shelves</b>			
TWTS7218H3	72"W x 18"D Tilted Shelf with High Pressure Laminate Surface		1,514.00
TWTS7218ES	72"W x 18"D Tilted Shelf with ESD Laminate Surface		1,778.00

## FIXED CANTILEVERED - CORNER SHELVES

Fixed Cantilevered Corner Shelves provide general storage. Shelves can be used with Corner and L-Shaped Organizer frames only (not compatible with straight organizer frames).

- Shelf weight capacity is 250 lbs.
- Shelves are adjustable on 1" increments
- Shelves install and can be relocated for easy adaptability

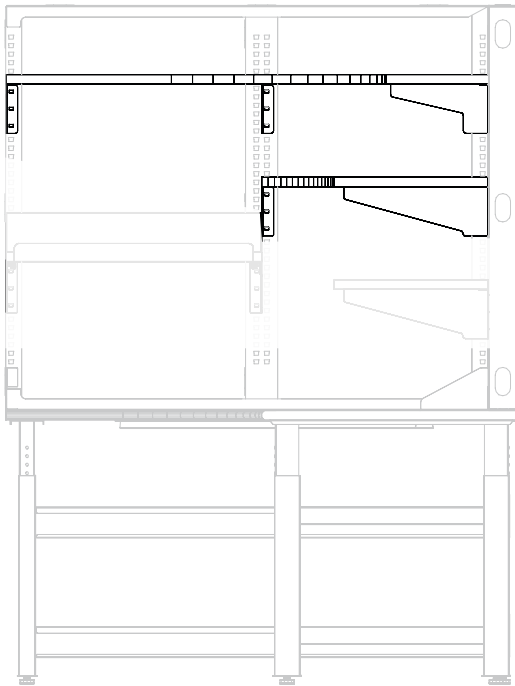

FRONT

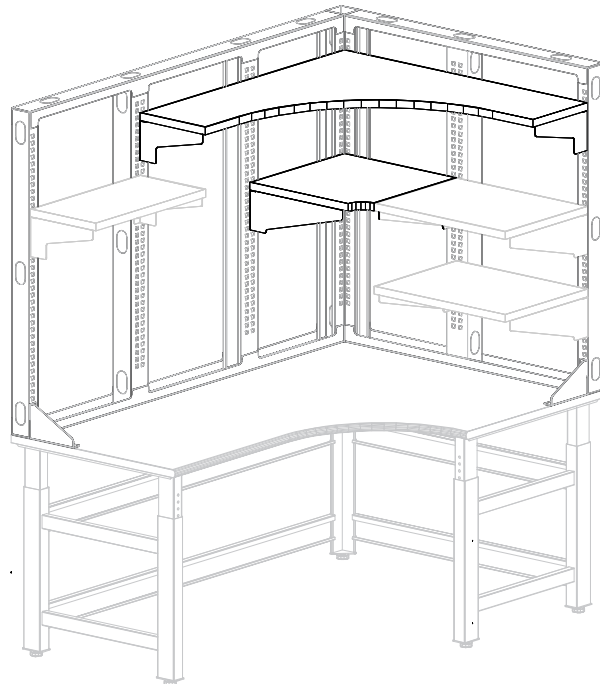

Placement of corner shelves on an L-Shaped frame

### HOW TO SPECIFY

1. Choose the shelf material	2. Choose the shelf width that matches your organizer frame	3. Choose the shelf depth	4. Choose the shelf finish
HPL	24"	12"	Shelf laminate color (if applicable)
ESD*	30"	18"	Shelf edge band color
	36"		Powder coat paint color
	48" (Use with 72" x 48" L-Shaped applications)		(See options on pg. 2)
	60"		

\*Includes grounding terminus; coordinating accessories available on pg. 65

Item No.	Description	Weight (lbs.)	List Price
----------	-------------	---------------	------------

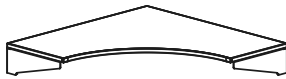

TWCS4818H3

## 12"D FIXED CANTILEVERED CORNER SHELVES

### 24"W Shelves

TWCS2412H3	24"W x 12"D Corner Shelf with High Pressure Laminate Surface	32	1,057.00
TWCS2412ES	24"W x 12"D Corner Shelf with ESD Laminate Surface	32	1,209.00

### 30"W Shelves

TWCS3012H3	30"W x 12"D Corner Shelf with High Pressure Laminate Surface	40	1,125.00
TWCS3012ES	30"W x 12"D Corner Shelf with ESD Laminate Surface	40	1,278.00

### 36"W Shelves

TWCS3612H3	36"W x 12"D Corner Shelf with High Pressure Laminate Surface	47	1,190.00
TWCS3612ES	36"W x 12"D Corner Shelf with ESD Laminate Surface	47	1,344.00

### 48"W Shelves

TWCS4812H3	48"W x 12"D Corner Shelf with High Pressure Laminate Surface*	64	1,309.00
TWCS4812ES	48"W x 12"D Corner Shelf with ESD Laminate Surface*	64	1,472.00

\*Use 48"W Corner Shelf for 72 x 48"W "L" Corner Upper Frame applications.

### 60"W Shelves

TWCS6012H3	60"W x 12"D Corner Shelf with High Pressure Laminate Surface	80	1,430.00
TWCS6012ES	60"W x 12"D Corner Shelf with ESD Laminate Surface	80	1,751.00

## 18"D FIXED CANTILEVERED CORNER SHELVES

### 24"W Shelves

TWCS2418H3	24"W x 18"D Corner Shelf with High Pressure Laminate Surface	42	1,410.00
TWCS2418ES	24"W x 18"D Corner Shelf with ESD Laminate Surface	42	1,610.00

### 30"W Shelves

TWCS3018H3	30"W x 18"D Corner Shelf with High Pressure Laminate Surface	53	1,496.00
TWCS3018ES	30"W x 18"D Corner Shelf with ESD Laminate Surface	53	1,705.00

### 36"W Shelves

TWCS3618H3	36"W x 18"D Corner Shelf with High Pressure Laminate Surface	64	1,586.00
TWCS3618ES	36"W x 18"D Corner Shelf with ESD Laminate Surface	64	1,792.00

### 48"W Shelves

TWCS4818H3	48"W x 18"D Corner Shelf with High Pressure Laminate Surface*	85	1,749.00
TWCS4818ES	48"W x 18"D Corner Shelf with ESD Laminate Surface*	64	1,961.00

\*Use 48"W Corner Shelf for 72 x 48"W "L" Corner Upper Frame applications.

### 60"W Shelves

TWCS6018H3	60"W x 18"D Corner Shelf with High Pressure Laminate Surface	106	1,906.00
TWCS6018ES	60"W x 18"D Corner Shelf with ESD Laminate Surface	106	2,121.00

# BASE SHELVES FOR STRAIGHT BENCH

Straight base shelves are constructed from 14-gage cold rolled steel and provide general storage below the work surface of TechWorks Straight Benches. Available in full depth (23" deep) or partial depth (12" deep) and can be attached to TechWorks benches in two preset locations (lower or upper cross bars on the bench base legs).

- 24" deep benches can only accommodate partial base shelves
- Weight Capacity of Full Base or Partial Base Shelf is 400 lbs. each
- Full Base shelves can be used with 30" or 36" deep benches only
- Full Base shelf on 96" wide benches is only 18" deep

Shelf shown on Straight Bench



FRONT

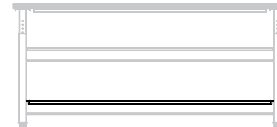

## HOW TO SPECIFY

1. Choose the shelf width that matches your bench		2. Choose the shelf depth	3. Choose the shelf finish
24"	60"	Partial Base Shelf - 12"	Powder coat paint color (See options on pg. 2)
30"	72"	Full Base Shelf - 23" (*if 96"W is requested, shelf will be 18")	
36"	96"*		
48"			

Item No.	Description	Weight (lbs.)	List Price
----------	-------------	---------------	------------

## BASE SHELVES - STRAIGHT BENCH



### Full Base Shelf

TWFBS2423	24"W x 23"D, Full Base Shelf	15	425.00
TWFBS3023	30"W x 23"D, Full Base Shelf	21	444.00
TWFBS3623	36"W x 23"D, Full Base Shelf	27	462.00
TWFBS4823	48"W x 23"D, Full Base Shelf	33	521.00
TWFBS6023	60"W x 23"D, Full Base Shelf	39	595.00
TWFBS7223	72"W x 23"D, Full Base Shelf	47	642.00
TWFBS9618	96"W x 18"D, Full Base Shelf	66	779.00

### Partial Base Shelf

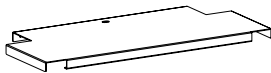

TWPBS3012

TWPBS2412	24"W x 12"D, Partial Base Shelf	10	231.00
TWPBS3012	30"W x 12"D, Partial Base Shelf	11	246.00
TWPBS3612	36"W x 12"D, Partial Base Shelf	13	271.00
TWPBS4812	48"W x 12"D, Partial Base Shelf	16	328.00
TWPBS6012	60"W x 12"D, Partial Base Shelf	19	403.00
TWPBS7212	72"W x 12"D, Partial Base Shelf	22	457.00
TWPBS9612	96"W x 12"D, Partial Base Shelf	32	532.00



## BASE SHELVES FOR CORNER & L-SHAPED BENCHES

Corner base shelves are constructed from 14-gage cold rolled steel and provide general storage below the work surface of TechWorks Corner and L-Shaped Benches. Available in full depth (23" deep) or partial depth (12" deep) and can be attached to TechWorks benches in two preset locations (lower or upper cross bars on the bench base legs).

- Weight Capacity of Full Base or Partial Base Shelf is 400 lbs. each
- Corner base shelves can only be installed along one side of the corner unit
- Only one shelf can be used per upper or lower cross bar

Shelf shown on L-Shaped Bench

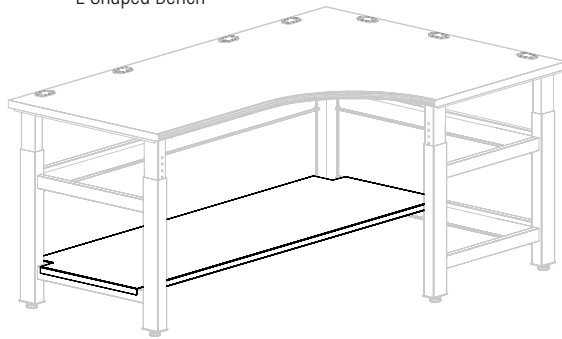

FRONT

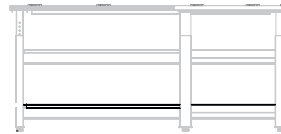

### HOW TO SPECIFY

1. Choose the shelf width that matches your bench		2. Choose the shelf depth	3. Choose the shelf finish
24"	48"	Partial Base Shelf - 12"	Powder coat paint color (See options on pg. 2)
30"	60"	Full Base Shelf - 23"	
36"	72"		

Item No.	Description	Weight (lbs.)	List Price
----------	-------------	---------------	------------

### BASE SHELVES - CORNER BENCH

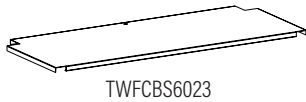

TWFCBS6023

#### Full Corner Base Shelf

TWFCBS4823	48"W x 23"D, Full Corner Base Shelf	33	519.00
TWFCBS6023	60"W x 23"D, Full Corner Base Shelf	39	561.00
TWFCBS7223	72"W x 23"D, Full Corner Base Shelf	47	656.00

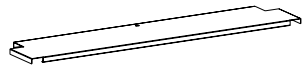

TWPCBS6012

#### Partial Corner Base Shelf

TWPCBS4812	48"W x 12"D, Partial Corner Base Shelf	16	344.00
TWPCBS6012	60"W x 12"D, Partial Corner Base Shelf	19	421.00
TWPCBS7212	72"W x 12"D, Partial Corner Base Shelf	22	471.00

# PEG BOARD PANELS FOR ORGANIZER FRAMES

TechWorks Peg Board attaches between organizer frames for the storage of small tools and other items within arm's reach. Peg Boards can be mounted on front or back of the frame to give a finished appearance from either side.

- Peg boards easily attach to the organizer frame with lift-and-hook assembly
- Telecom Channel and Dual Sided Power Strip hook on components can't be put in front of Peg Boards
- Peg board hooks not included
- Constructed of durable brown Masonite
- Peg boards are surrounded by steel frames (refer to Techworks paint options to specify)

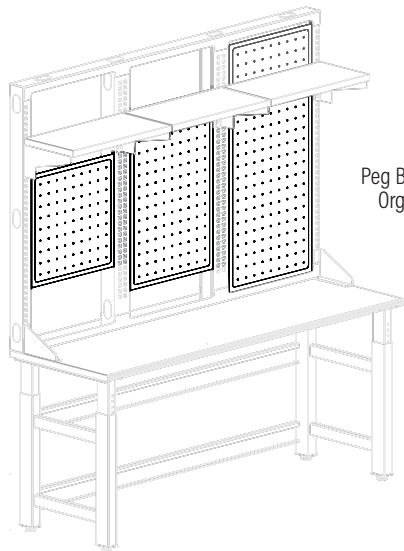

Peg Board shown on Organizer Frame

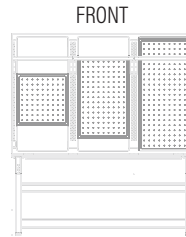

## HOW TO SPECIFY

1. Choose the peg board width that matches your organizer frame section		2. Choose the peg board height that matches your organizer frame	3. Choose the peg board frame finish
For straight frame applications: 24" 30" 36"	For corner inner section applications: 20" 26" 32"	24"* 36"* 48"  *24" and 36" panels can be specified for 48" frames, 24" panel can be specified for 36" frame (Mountable at 5" increments)	Powder coat paint color for peg board frames and steel peg board option  Powder coat paint can be matched to TechWorks organizer frame  (See options on pg. 2)

Item No. Description Weight (lbs.) List Price

### MASONITE PEG BOARD PANELS

TWPGM2424	24"W x 24"H, Masonite Peg Board	6	390.00
TWPGM2436	24"W x 36"H, Masonite Peg Board	7	461.00
TWPGM2448	24"W x 48"H, Masonite Peg Board	8	537.00
TWPGM3024	30"W x 24"H, Masonite Peg Board	7	424.00
TWPGM3036	30"W x 36"H, Masonite Peg Board	8	495.00
TWPGM3048	30"W x 48"H, Masonite Peg Board	9	585.00
TWPGM3624	36"W x 24"H, Masonite Peg Board	7	438.00
TWPGM3636	36"W x 36"H, Masonite Peg Board	8	510.00
TWPGM3648	36"W x 48"H, Masonite Peg Board	9	568.00

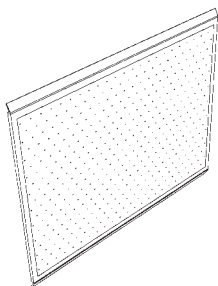

TWPGM3036

Item No. Description Weight (lbs.) List Price

**MAGNETIC STEEL PEG BOARD PANELS**

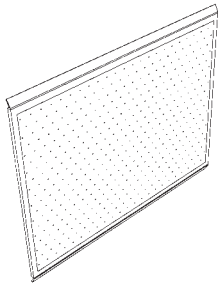

TWPGM3036

TWPGS2424	24"W x 24"H, Magnetic Steel Peg Board	9	430.00
TWPGS2436	24"W x 36"H, Magnetic Steel Peg Board	14	508.00
TWPGS2448	24"W x 48"H, Magnetic Steel Peg Board	18	588.00
TWPGS3024	30"W x 24"H, Magnetic Steel Peg Board	11	465.00
TWPGS3036	30"W x 36"H, Magnetic Steel Peg Board	17	545.00
TWPGS3048	30"W x 48"H, Magnetic Steel Peg Board	22	609.00
TWPGS3624	36"W x 24"H, Magnetic Steel Peg Board	13	482.00
TWPGS3636	36"W x 36"H, Magnetic Steel Peg Board	20	564.00
TWPGS3648	36"W x 48"H, Magnetic Steel Peg Board	27	626.00

**CORNER MASONITE PEG BOARD PANELS**

TWPGCM2024	20"W x 24"H, Corner Masonite Peg Board	5	390.00
TWPGCM2036	20"W x 36"H, Corner Masonite Peg Board	6	461.00
TWPGCM2048	20"W x 48"H, Corner Masonite Peg Board	7	537.00

\*For use in the inner corner frame sections of the 72" x 48"W "L", 24"W and 48"W Corner Organizer Frames

TWPGCM2624	26"W x 24"H, Corner Masonite Peg Board	6	407.00
TWPGCM2636	26"W x 36"H, Corner Masonite Peg Board	7	474.00
TWPGCM2648	26"W x 48"H, Corner Masonite Peg Board	8	548.00

\*For use in the inner corner frame sections of the 30"W and 60"W Corner Organizer Frames

TWPGCM3224	32"W x 24"H, Corner Masonite Peg Board	7	407.00
TWPGCM3236	32"W x 36"H, Corner Masonite Peg Board	8	474.00
TWPGCM3248	32"W x 48"H, Corner Masonite Peg Board	9	548.00

\*For use in the inner corner frame sections of the 36"W Corner Organizer Frames

**CORNER MAGNETIC STEEL PEG BOARD PANELS**

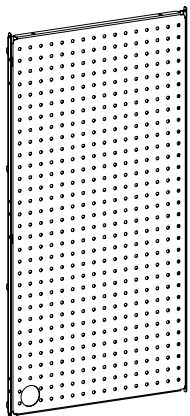

TWPGCS2036

TWPGCS2024	20"W x 24"H, Corner Magnetic Steel Peg Board	8	430.00
TWPGCS2036	20"W x 36"H, Corner Magnetic Steel Peg Board	12	508.00
TWPGCS2048	20"W x 48"H, Corner Magnetic Steel Peg Board	15	588.00

\*For use in the inner corner frame sections of the 72" x 48"W "L", 24"W and 48"W Corner Organizer Frames

TWPGCS2624	26"W x 24"H, Corner Magnetic Steel Peg Board	10	446.00
TWPGCS2636	26"W x 36"H, Corner Magnetic Steel Peg Board	15	522.00
TWPGCS2648	26"W x 48"H, Corner Magnetic Steel Peg Board	20	601.00

\*For use in the inner corner frame sections of the 30"W and 60"W Corner Organizer Frames

TWPGCS3224	32"W x 24"H, Corner Magnetic Steel Peg Board	12	446.00
TWPGCS3236	32"W x 36"H, Corner Magnetic Steel Peg Board	18	522.00
TWPGCS3248	32"W x 48"H, Corner Magnetic Steel Peg Board	24	601.00

\*For use in the inner corner frame sections of the 36"W Corner Organizer Frames

# WHITEBOARD PANELS FOR ORGANIZER FRAMES

TechWorks Whiteboards attach between organizer frames and create a private work environment to help support increased focus in busy work areas. The magnetic steel panels are finished with a whiteboard coating on both the front and back sides to provide a finished look and double your usable surface.

- Quick install via adapter bars inside frame for lift-and-hook placement
- Telecom Channel and Dual Sided Power Strip hook on components cannot be put in front of whiteboards
- Optional marker trays available (1-per whiteboard, not compatible with "inside" corner frame sections)
- Steel panel with dry erase powder coat surface allows for writing on, and also can be used as a magnetic board

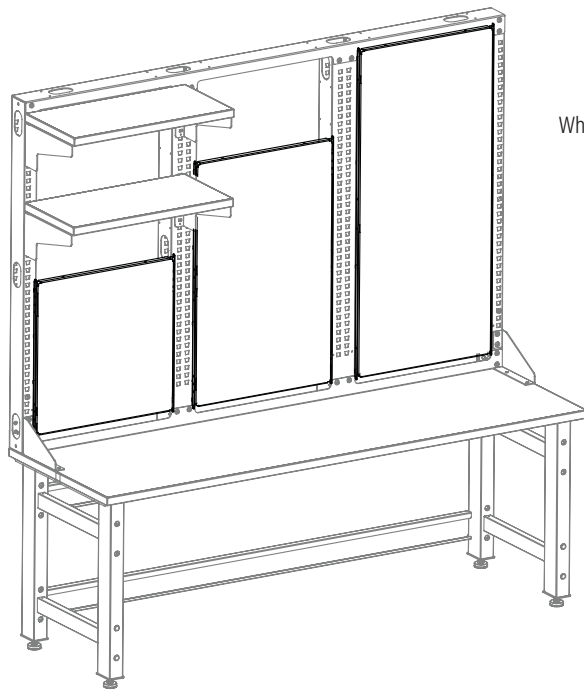

White Boards shown on Organizer Frame

## HOW TO SPECIFY

1. Choose the whiteboard width that matches your organizer frame section		2. Choose the whiteboard height that matches your organizer frame
For straight frame applications:	For corner "inside" section applications:	24"* 36"* 48"
24"	20"	*24" and 36" panels can be specified for 48" frames, 24" panel can be specified for 36" frame (Mountable at 5" increments)
30"	26"	
36"	32"	

Item No. Description Weight (lbs.) List Price

**WHITEBOARD PANELS**

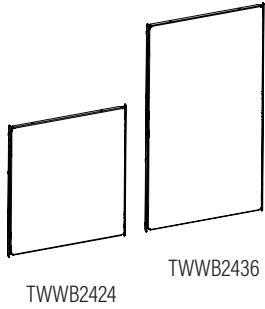

TWWB2424	24"W x 24"H, Magnetic Whiteboard	10	390.00
TWWB2436	24"W x 36"H, Magnetic Whiteboard	15.5	475.00
TWWB2448	24"W x 48"H, Magnetic Whiteboard	20	560.00
TWWB3024	30"W x 24"H, Magnetic Whiteboard	12.5	424.00
TWWB3036	30"W x 36"H, Magnetic Whiteboard	18.5	510.00
TWWB3048	30"W x 48"H, Magnetic Whiteboard	24.5	579.00
TWWB3624	36"W x 24"H, Magnetic Whiteboard	15	455.00
TWWB3636	36"W x 36"H, Magnetic Whiteboard	22.5	524.00
TWWB3648	36"W x 48"H, Magnetic Whiteboard	29.5	612.00

**CORNER WHITEBOARD PANELS**

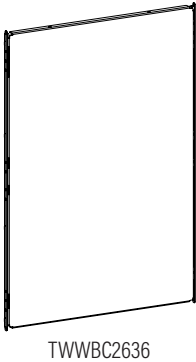

TWWBC2024	20"W x 24"H, Corner Magnetic Whiteboard*	8.5	384.00
TWWBC2036	20"W x 36"H, Corner Magnetic Whiteboard*	12.5	456.00
TWWBC2048	20"W x 48"H, Corner Magnetic Whiteboard*	16.5	568.00
*For use in the inner corner frame sections of the 72" x 48"W "L", 24"W and 48"W Corner Organizer Frames			
TWWBC2624	26"W x 24"H, Corner Magnetic Whiteboard*	10.5	398.00
TWWBC2636	26"W x 36"H, Corner Magnetic Whiteboard*	16.5	491.00
TWWBC2648	26"W x 48"H, Corner Magnetic Whiteboard*	21.5	567.00
*For use in the inner corner frame sections of the 30"W and 60"W Corner Organizer Frames			
TWWBC3224	32"W x 24"H, Corner Magnetic Whiteboard*	13.5	468.00
TWWBC3236	32"W x 36"H, Corner Magnetic Whiteboard*	20	456.00
TWWBC3248	32"W x 48"H, Corner Magnetic Whiteboard*	26.5	568.00
*For use in the inner corner frame sections of the 36"W Corner Organizer Frames			

**WHITEBOARD PANELS ACCESSORIES**

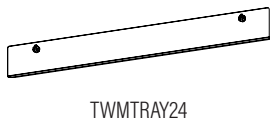

TWMTRAY24	24"W, Marker Tray for Whiteboard	1	106.00
TWMTRAY30	30"W, Marker Tray for Whiteboard	1.5	114.00
TWMTRAY36	36"W, Marker Tray for Whiteboard	2	137.00

## FABRIC PANELS FOR ORGANIZER FRAMES

TechWorks Fabric Panels attach between organizer frames to create a private work environment and help support increased focus in busy work areas. Screens can be mounted on front or back of the frame to give a finished appearance from either side.

- Steel frames surround the fabric screens with lift-and-hook for assembly
- Telecom Channel and Dual Sided Power Strip hook on components cannot be put in front of Fabric Panels
- Fabric Panels can also be used as a tack board
- Additional fabrics are available with extended lead times and upcharges may apply. Email [specials@safcoproducts.com](mailto:specials@safcoproducts.com) for quotation.

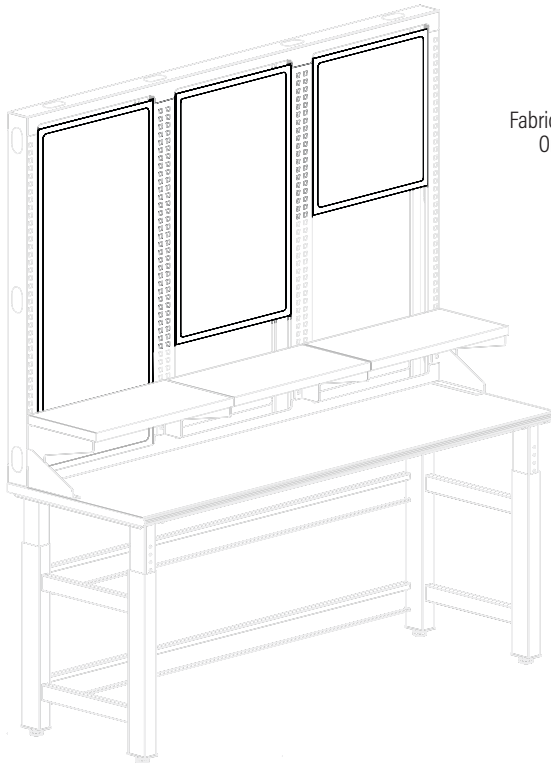

Fabric Panels shown on Organizer Frame

### HOW TO SPECIFY

1. Choose the fabric screen width that matches your organizer frame section		2. Choose the fabric screen height that matches your organizer frame	3. Choose the fabric screen frame finish
For straight frame applications: 24" 30" 36"	For corner "inside" section applications: 20" 26" 32"	24"* 36"* 48"  *24" and 36" panels can be specified for 48" frames, 24" panel can be specified for 36" frame (Mountable at 5" increments)	Powder coat paint color for frame around fabric panel  Powder coat paint can be matched to TechWorks organizer frame  Fabric Selection  (See options on pg. 2)

Item No. Description Weight (lbs.) List Price

**FABRIC PANELS**

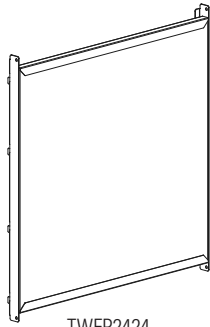

TWFP2424

TWFP2424	24"W x 24"H, Fabric Panel	6	490.00
TWFP2436	24"W x 36"H, Fabric Panel	7	553.00
TWFP2448	24"W x 48"H, Fabric Panel	8	737.00
TWFP3024	30"W x 24"H, Fabric Panel	6	550.00
TWFP3036	30"W x 36"H, Fabric Panel	7	613.00
TWFP3048	30"W x 48"H, Fabric Panel	8	719.00
TWFP3624	36"W x 24"H, Fabric Panel	6	543.00
TWFP3636	36"W x 36"H, Fabric Panel	7	632.00
TWFP3648	36"W x 48"H, Fabric Panel	8	738.00

**CORNER FABRIC PANELS**

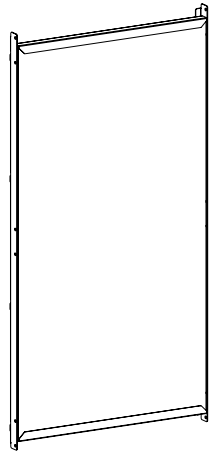

TWFC2036

TWFC2024	20"W x 24"H, Corner Fabric Panel*	6	472.00
TWFC2036	20"W x 36"H, Corner Fabric Panel*	7	540.00
TWFC2048	20"W x 48"H, Corner Fabric Panel*	8	650.00
*For use in the inner corner frame sections of the 72" x 48"W "L", 24"W and 48"W Corner Organizer Frames			
TWFC2624	26"W x 24"H, Corner Fabric Panel*	6	477.00
TWFC2636	26"W x 36"H, Corner Fabric Panel*	7	548.00
TWFC2648	26"W x 48"H, Corner Fabric Panel*	8	659.00
*For use in the inner corner frame sections of the 30"W and 60"W Corner Organizer Frames			
TWFC3224	32"W x 24"H, Corner Fabric Panel*	6	518.00
TWFC3236	32"W x 36"H, Corner Fabric Panel*	7	603.00
TWFC3248	32"W x 48"H, Corner Fabric Panel*	8	707.00
*For use in the inner corner frame sections of the 36"W Corner Organizer Frames			

## OVERHEAD STORAGE BIN FOR ORGANIZER FRAMES

TechWorks Overhead Storage bin provides secure storage. Door swings up and over the cabinet to optimize interiors storage space.

- Overhead Storage bin placement adjustable in 1" increments
- Storage bins can install and be relocated for easy adaptability
- Storage bins can be placed side-by-side on frame
- Door lock is standard, locks are keyed differently
- Non-removable core

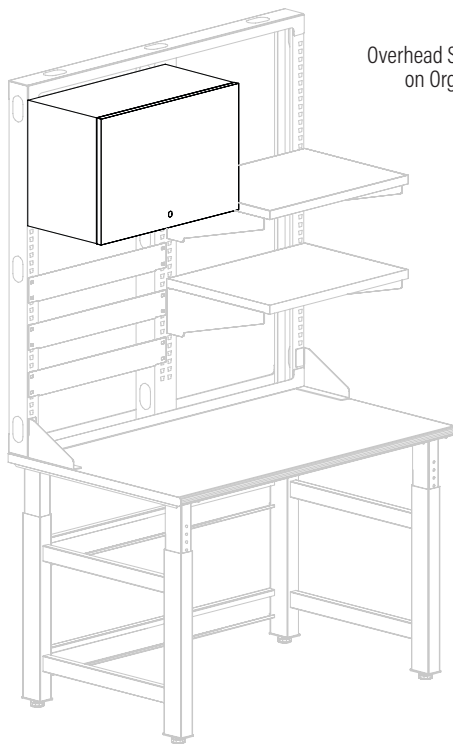

Overhead Storage Bin shown on Organizer Frame

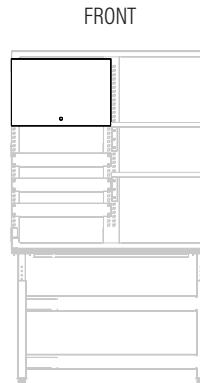

FRONT

### HOW TO SPECIFY

1. Choose the overhead storage width that matches your organizer frame section	2. Choose the overhead storage bin finish
24" compatible with 24", 48", 72" and 96"W Benches	Powder coat paint color
30" compatible with 30" and 60"W Benches	Powder coat paint can be matched to TechWorks organizer frame
36" compatible with 36"W Benches only	(See options on pg. 2)

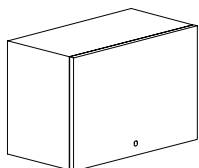

Item No.	Description	Weight (lbs.)	List Price
<b>OVERHEAD STORAGE BINS</b>			
TWOHST24	24"W x 12"D x 16"H, Lockable Overhead Storage Bin	37	1,350.00
TWOHST30	30"W x 12"D x 16"H, Lockable Overhead Storage Bin	50	1,637.00
TWOHST36	36"W x 12"D x 16"H, Lockable Overhead Storage Bin	62	1,861.00



# PART BIN STRIP FOR ORGANIZER FRAMES

TechWorks Parts bin panels accept part bins (Bins not included-available from multiple vendors) which are ideal for storage and organization of small items.

- 24", 30", 36", 48", 60" and 72"W organizer frames accept multiple bin strips
- Accepts optional part bins from multiple vendors
- Bin panels can install and be relocated for easy adaptability
- All bin strips are 3" high

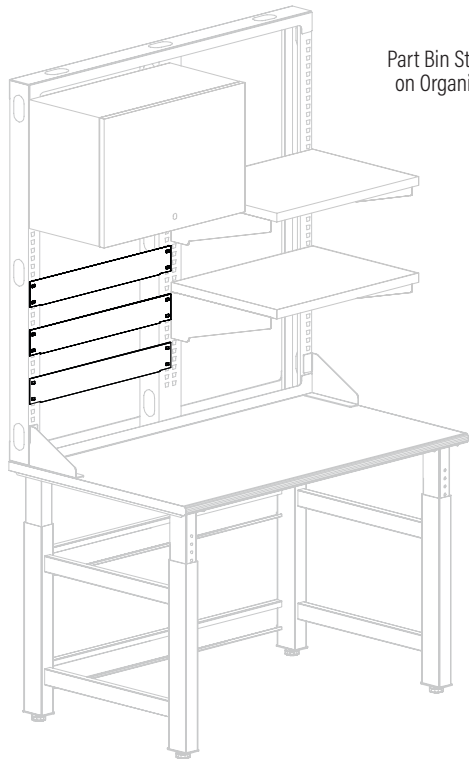

Part Bin Strips shown on Organizer Frame

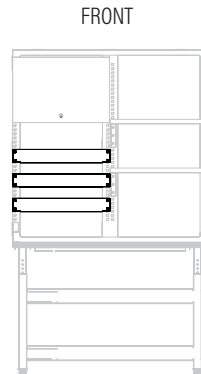

FRONT

## HOW TO SPECIFY

1. Choose the bin strip width that matches your organizer frame section	2. Choose the parts bin strip panels finish
24"	Powder coat paint color
30"	Powder coat paint can be matched to TechWorks organizer frame
36"	(See options on pg. 2)

Item No.	Description	Weight (lbs.)	List Price
----------	-------------	---------------	------------

### PART BIN STRIPS

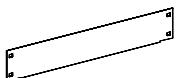

TWBINSTP24	24"W x 3"H, Part Bin Strip	3	140.00
TWBINSTP30	30"W x 3"H, Part Bin Strip	4	157.00
TWBINSTP36	36"W x 3"H, Part Bin Strip	5	175.00

# SUSPENDED TOTE HOLDER AND TOTE KITS FOR BENCH STORAGE

TechWorks Tote holder provides storage of totes below the work surface and is compatible with all TechWorks benches.

- Totes and glides are not included with tote holder and must be specified separately
- Tote holder can hold up to 5-3"H totes, 2-6"H totes, 1-9"H tote or 1-12"H tote if the bench has a base shelf
- Tote holder can hold up to 5-3"H totes, 2-6"H totes, 2-9"H totes or 2-12"H totes if the bench does not have a base shelf
- Tote kits come standard with tote(s), glides, hardware bag, and optional use mobile stop clips
- Tote weight capacities: 3"H-10 lbs. per tote, 6"H, 9"H and 12"H-20 lbs. per tote

Totes and Glides shown with Tote Holder

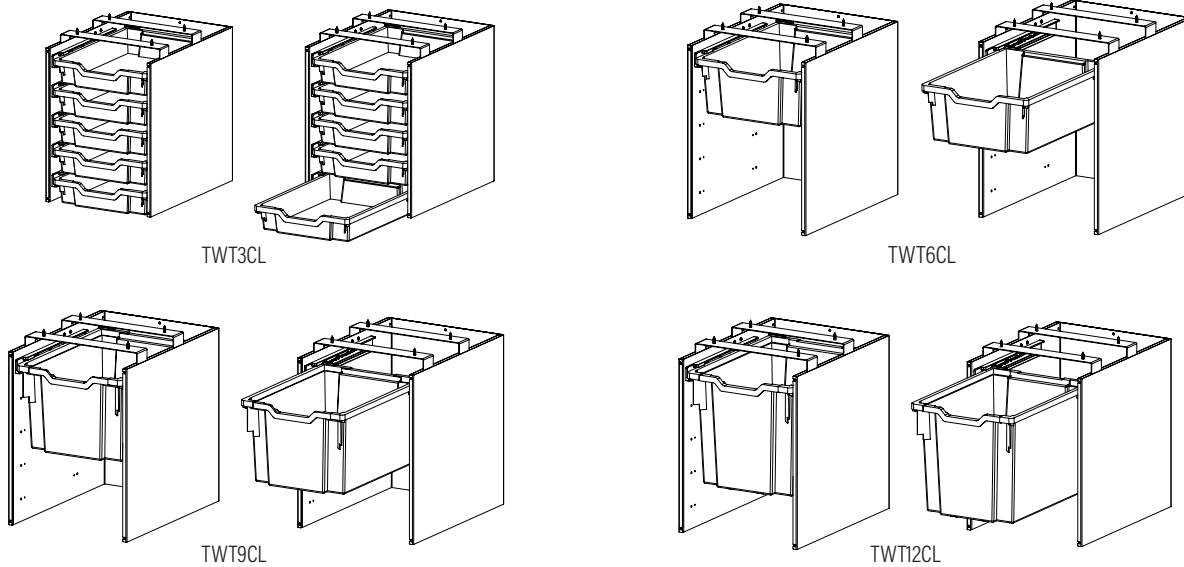

## HOW TO SPECIFY

1. Choose the tote holder (TWTH) finish	2. Choose your tote and glide kit
Powder coat paint color (if applicable) Powder coat paint can be matched to TechWorks bench frame (See options on pg. 2)	TWT3CL - 3"H tote (5 pk) TWT6CL - 6"H tote (1 pk) TWT9CL - 9"H tote (1 pk) TWT12CL - 12"H tote (1 pk)

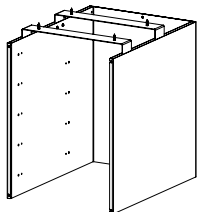

TWTH  
Tote Holder

Item No.	Description	Weight (lbs.)	List Price
<b>TOTE HOLDER AND TOTE KITS</b>			
<b>Tote Holder</b>			
TWTH	Suspended Tote Holder	33	559.00
<b>Tote Kits</b> (shown above)			
TWT3CL	12 ¼"W x 16 ¾"D x 3"H, Clear Totes, 5 Pack with 10 Glides	7	181.00
TWT6CL	12 ¼"W x 16 ¾"D x 6"H, Clear Totes, 1 Pack with 2 Glides	3	42.00
TWT9CL	12 ¼"W x 16 ¾"D x 9"H, Clear Totes, 1 Pack with 2 Glides	3	56.00
TWT12CL	12 ¼"W x 16 ¾"D x 12"H, Clear Totes, 1 Pack with 2 Glides	3	75.00

## PEDESTAL FILE FOR BENCH STORAGE

Pedestals have a two-drawer Box/File configuration with each drawer featuring full width drawer pulls and full extension precision ball-bearing slides. File drawers accommodate letter-size files

- Box/File Pedestal in a two drawer configuration
- Full width drawer pull
- File drawers accommodate letter-size files
- Fixed, mobile or work surface suspended models available
- Suspended pedestal not compatible with TechWorks Corner Benches and L-Shaped Benches
- The suspended pedestal in combination with a base shelf will require the bench work surface to be placed no lower than 32" from the floor
- Locks standard with core removable locks
- Full extension precision ball-bearing slides
- Optional faux Black Leather cushion available transforms pedestal into a seat (adds 2" to height)
- Mobile pedestal in Black-S5 or Silver-HK5

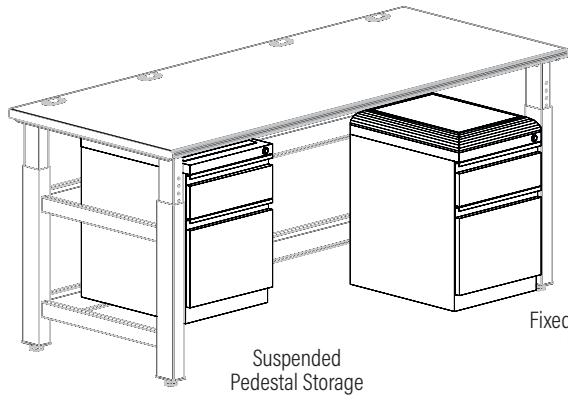

Suspended Pedestal Storage

Fixed Pedestal Storage with Cushion

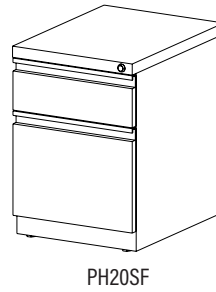

PH20SF

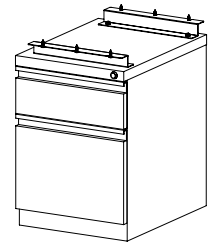

PH20SW

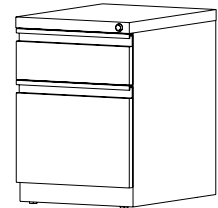

PH20SM

### HOW TO SPECIFY

1. Choose the model	2. Choose the pedestal paint color for fixed or mobile pedestal	3. Choose the suspended pedestal finish	4. Add optional cushion to fixed or mobile pedestal
Fixed-Freestanding Mobile-Freestanding Suspended (Mounts under TechWorks bench work surfaces)	Black (S5) Silver (HK5)	Powder coat paint color Powder coat paint can be matched to TechWorks bench frame (See options on pg. 2)	Item CSH20

Item No.	Description	Weight (lbs.)	List Price
----------	-------------	---------------	------------

### PEDESTAL STORAGE

Pedestal Files	(shown above)		
PH20SM	15"W x 20"D x 21 3/4"H, Box/File Mobile Pedestal	60	625.00
PH20SF	15"W x 20"D x 21 3/4"H, Box/File Fixed Pedestal	60	625.00
PH20SW	15"W x 20"D x 21 3/4"H, Box/File Suspended Pedestal*	55	784.00

\*For mounting under TechWorks bench surface

#### Optional Cushion

CSH20	Black Faux Leather Cushion, Velcro® attached (For use with fixed and mobile pedestals only)	6	332.00
-------	---	---	--------

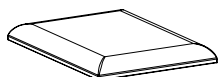

CSH20

## UTILITY DRAWER FOR BENCH STORAGE

Utility Drawer mounts under the work surface and provides storage for office accessories and other small items.

- Benches 30"W or larger can accommodate up to 1 utility drawer; Benches 48"W or larger can accommodate up to 2 utility drawers
- Utility drawer not compatible with TechWorks Electric Height-Adjustable Benches, Corner Benches, and L-Shaped Benches
- Locking drawer mounts under front of work surface: Lock is Standard
- All hardware included

Utility Drawers shown  
on Straight Bench

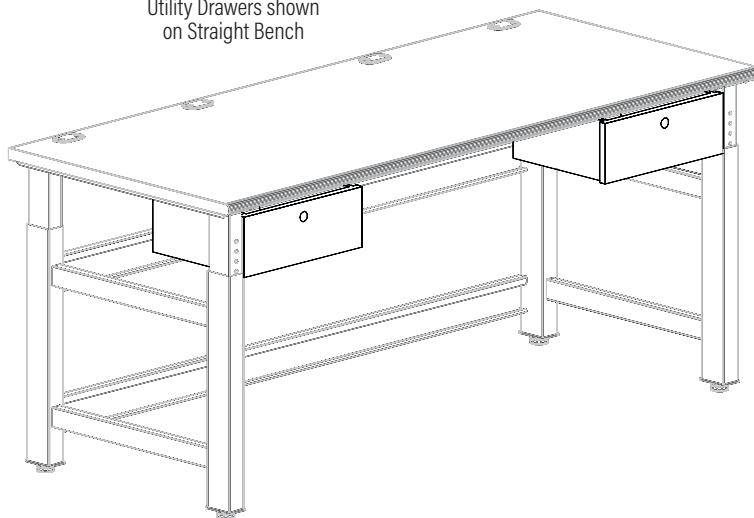

FRONT

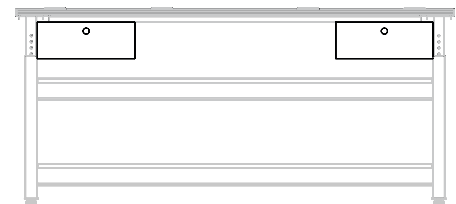

### HOW TO SPECIFY

#### 1. Choose the utility drawer finish

Powder coat paint color  
 Powder coat paint can be matched  
 to TechWorks bench frame  
 (See options on pg. 2)

Item No.	Description	Weight (lbs.)	List Price
<b>UTILITY DRAWER</b>			
TWDRWR	16"W x 12 ½"D x 6"H, Utility Drawer with Lock	5	741.00

## PULL-OUT WRITING SHELF FOR BENCH STORAGE

Pull Out Writing Shelf mounts under the Bench work surface and pulls out on two glides to provide additional work space.

- Writing Shelf pulls-out from under work surface on two glides
- Pull-out writing shelf not compatible with TechWorks Electric Height-Adjustable Benches, Corner Benches, and L-Shaped Benches
- Supports a maximum of 60 lbs.
- 20"W writing surface
- Can be specified to be same material as work surface. Available in HPL only.

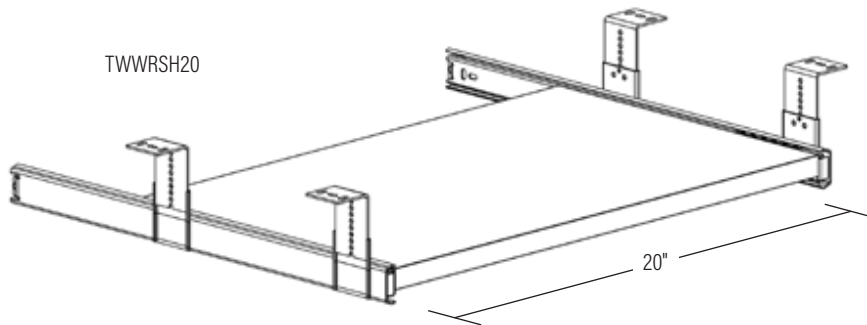

### HOW TO SPECIFY

**1. Choose the Pull-Out Shelf finish**

- HPL Color
- Edge Band Color
- (See options on pg. 2)

Item No.	Description	Weight (lbs.)	List Price
<b>PULL-OUT WRITING SHELF</b>			
TWWRSH20	20"W x 12 ¼"D, Pull-Out Writing Shelf	19	382.00

## STORAGE CENTER BASE AND TOP

- Storage Center consists of: Top work surface, Center Frame, Side Frames and Spreader
- Work surfaces available:
  - HPL (High Pressure Laminate 1 1/8" thick) with 3mm PVC edge band on all sides
  - Butcher Block (1 3/4" thick) 1/8" radius on all sides
  - ESD (Electro-Static Discharge 1 1/8" thick) with ground terminus. ESD available in Gray laminate with Black edge banding only (coordinating accessories available on pg. 65)
- Storage Centers can be joined together with optional ganging hardware to create a unique work environment
- Ships ready-to-assemble on 4-position oversized pallet
- 36" work surface is not interchangeable with 24"D or 30"D base

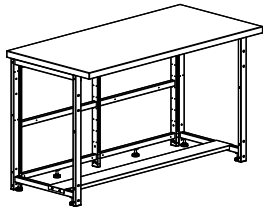
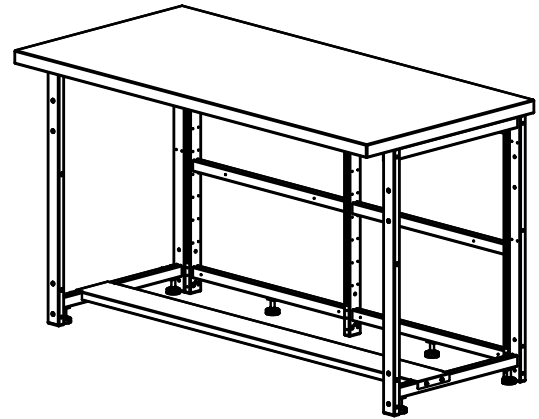

TWSTCR30H3

Item No.	Description	Weight (lbs.)	List Price
----------	-------------	---------------	------------

### STORAGE CENTER

High Pressure Laminate (HPL) Surface			
TWSTCR24H3	63"W x 24"D x 36"H		4,043.00
TWSTCR30H3	63"W x 30"D x 36"H (Top will overhang front by 6")		3,928.00
TWSTCR36H3	63"W x 36"D x 36"H		4,233.00
Butcher Block Surface			
TWSTCR24BB	63"W x 24"D x 36"H		4,072.00
TWSTCR30BB	63"W x 30"D x 36"H (Top will overhang front by 6")		4,756.00
TWSTCR36BB	63"W x 36"D x 36"H		5,162.00
ESD Surface			
TWSTCR24ES	63"W x 24"D x 36"H		3,865.00
TWSTCR30ES	63"W x 30"D x 36"H (Top will overhang front by 6")		4,221.00
TWSTCR36ES	63"W x 36"D x 36"H		4,564.00

## SIDE PANEL KITS FOR STORAGE CENTER

Panel kits can only be used on TechWorks Storage Centers

- Options for Modesty or Exterior Sides
- Water Resistant Resin
- Available Finishes: Millwork Cherry, Florence Walnut, White, Black Onyx

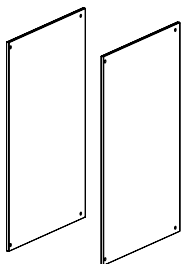

TWEXP30D

Item No.	Description	Weight (lbs.)	List Price
----------	-------------	---------------	------------

### SIDE PANEL KITS

TWEXP24D	24"W x 1/2"D x 34 3/4"H, Exterior Side Panels - Two each, For use with 24"D work surface	18	965.00
TWEXP30D	25 1/2"W x 1/2"D x 34 3/4"H, Exterior Side Panels - Two each, For use with 30"D work surface	30	1,029.00
TWEXP36D	35"W x 1/2"D x 34 3/4"H, Exterior Side Panels - Two each, For use with 36"D work surface	30	1,061.00
TWUMODP	27"W x 1/4"D x 29 1/2"H, Universal Modesty Panels - Two each	15	679.00

## MODULAR COMPONENTS FOR STORAGE CENTER

- Components are not compatible with Techworks Organizer Frames, Benches, or Tables
- Can be added to the underside of either the left and/or right front side of the Storage Center worktable, no more than 2 across
- Purchase optional tumblers to add locking capability to modular drawers

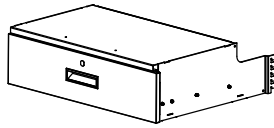

TWBOXDRW

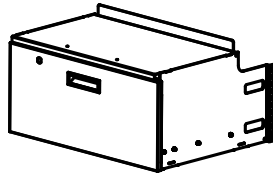

TWFILEDRW

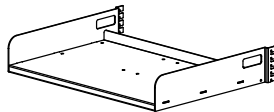

TWSTASH

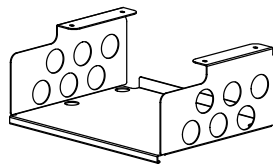

TWCUBBY

Item No.	Description	Weight (lbs.)	List Price
<b>MODULAR COMPONENTS</b>			
TWBOXDRW	28"W x 22 1/2"D x 8"H, Box Drawer (Optional lock available)	50	1,107.00
TWFILEDRW	28 1/2"W x 22 1/2"D x 13 1/2"H, Hanging File Drawer (Optional lock available)	69	1,312.00
TWSTASH	28 1/2"W x 22 1/2"D x 4 3/4"H, Stationary Shelf with Sides	37	303.00
TWCUBBY	13"W x 10"D x 5"H, Under surface Mount Cubby	7	163.00

## LOCKS FOR MODULAR COMPONENTS

Please read carefully to facilitate proper order or call Customer Care at 888-971-6225 for assistance. Storage Center Drawers are shipped with removable knockouts to add locking capability. Locks can be used with Storage Center components only.

- Locks can be added to drawers by ordering item numbers Q70800-Q70899
- To key alike suites of product, order the appropriate quantity of like numbered lock assemblies for each worktable
- Locks available in silver only

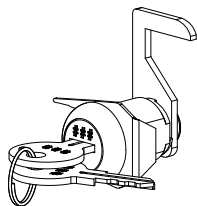

Q70800

Item No.	Description	Weight (lbs.)	List Price
<b>LOCKS FOR COMPONENTS</b>			
Q70800 through Q70899	Lock Assembly	1	36.00
Q629A	Master Key Removal Tool	1	36.00

## POWER STRIPS FOR ORGANIZER FRAMES OR BENCH MOUNTING

Techworks power strips mount in front of the organizer frames or under the work surface and include a lighted power switch with snap in guard. Each power strip includes a 15' power cord.

- All mounting hardware is included
- Not compatible with corner and L-shaped organizer frames "inner" sections
- It is recommended that you choose a power strip width that is less than the width of your bench to ensure proper fit in side-to-side benching applications
- Not compatible with TechWorks Electric Height-Adjustable Benches
- TWSPW2415, TWSPW481, TWSPW6015, TWSPW7215 mount horizontally outside the organizer frame or under the work surface. All other power strips mount to the organizer frame slots.

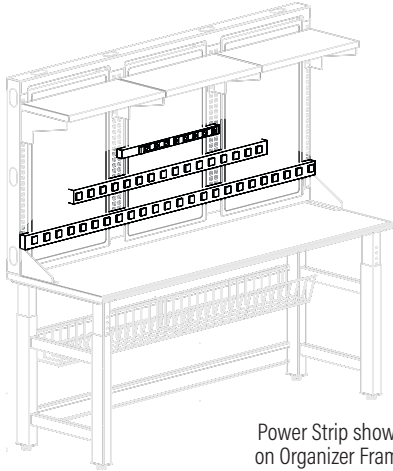

Power Strip shown on Organizer Frame

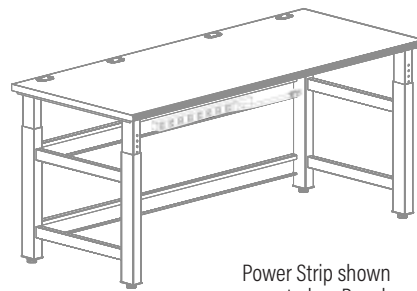

Power Strip shown mounted on Bench

### HOW TO SPECIFY

**1. Choose the desired power strip width**

- 24" (8 outlets)      60" (20 outlets)      48" (16 outlets)      72" (24 outlets)

## DUAL POWER STRIPS FOR ORGANIZER FRAMES

Techworks dual sided power strip mounts between the organizer frames and includes a lighted power switch with snap in guard. Each power strip includes 6 front outlets, 6 rear outlets and a 15' power cord.

- All mounting hardware is included
- Not compatible with corner and L-shaped organizer frames "inner" sections
- Not compatible with TechWorks Electric Height-Adjustable Benches

### HOW TO SPECIFY

1. Choose the power strip width that matches the organizer frame section	2. Choose the required AMPS	3. For 20 AMP options (only) match to the wall receptacle type
24"	15 AMP	NEMA 5-20R Wall Receptacle
30"	20 AMP	NEMA 5-L20R Wall Receptacle, Twist Lock
36"		

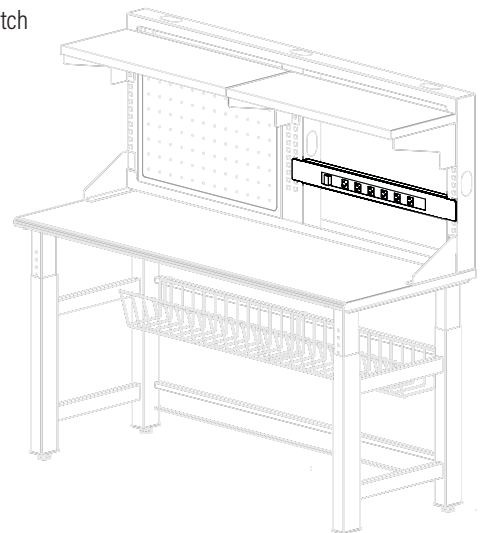



Item No.	Description	Weight (lbs.)	List Price
----------	-------------	---------------	------------

## POWER STRIPS

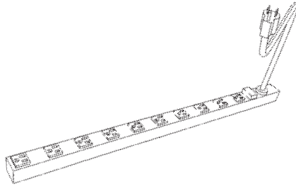

### Power Strips for Organizer Frames or Bench Mounting

TWSPW2415	24"W, 15 AMP Power Strip, 8 Outlets, 15' Cord	3	519.00
TWSPW4815	48"W, 15 AMP Power Strip, 16 Outlets, 15' Cord	4	590.00
TWSPW6015	60"W, 15 AMP Power Strip, 20 Outlets, 15' Cord	5	711.00
TWSPW7215	72"W, 15 AMP Power Strip, 24 Outlets, 15' Cord	6	740.00

Input: NEMA 5-15P, Output: NEMA 5-15R, Requires NEMA 5-15R Wall Receptacle

## DUAL POWER STRIPS

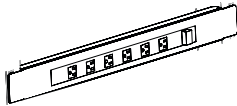

### Dual Power Strips 15 AMP

TWDPW2415	24"W, 15 AMP Power Strip, 6 Front/6 Back Outlets, 15' Cord	4	490.00
TWDPW3015	30"W, 15 AMP Power Strip, 6 Front/6 Back Outlets, 15' Cord	4	510.00
TWDPW3615	36"W, 15 AMP Power Strip, 6 Front/6 Back Outlets, 15' Cord	5	525.00

Input: NEMA 5-15P, Output: NEMA 5-15R, Requires NEMA 5-15R Wall Receptacle

### Dual Power Strips 20 AMP

TWDPW2420	24"W, 20 AMP Power Strip, 6 Front/6 Back Outlets, 15' Cord	4	651.00
TWDPW3020	30"W, 20 AMP Power Strip, 6 Front/6 Back Outlets, 15' Cord	4	671.00
TWDPW3620	36"W, 20 AMP Power Strip, 6 Front/6 Back Outlets, 15' Cord	5	686.00

Input: NEMA 5-20P, Output: NEMA 5-20R, Requires NEMA 5-20R Wall Receptacle

### Dual Power Strips 20 AMP with Twist Lock

TWDPW2420L	24"W, 20 AMP Power Strip, 6 Front/6 Back Outlets, 15' Cord, Twist Lock	6	674.00
TWDPW3020L	30"W, 20 AMP Power Strip, 6 Front/6 Back Outlets, 15' Cord, Twist Lock	6	694.00
TWDPW3620L	36"W, 20 AMP Power Strip, 6 Front/6 Back Outlets, 15' Cord, Twist Lock	6	709.00

Input: NEMA L5-20P, Output: NEMA 5-20R, Requires NEMA L5-20R Wall Receptacle, Twist Lock

# SERVICE BARS FOR BENCH MOUNTING

Service Bars mount under the work surface with mechanical fasteners and include opening for cable pass through and air, gas, and vacuum fixtures.

- Attached with wood screws to the underside of work surfaces or shelves
- Most service bars include powers strip (No power strip included with item TWSVBNP)
- Cable pass though not available on models without power strips
- Not compatible with TechWorks Electric Height-Adjustable Benches

Service Bar with Power Strip mounted on Bench

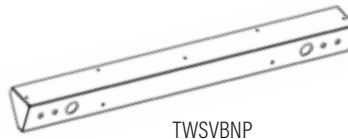
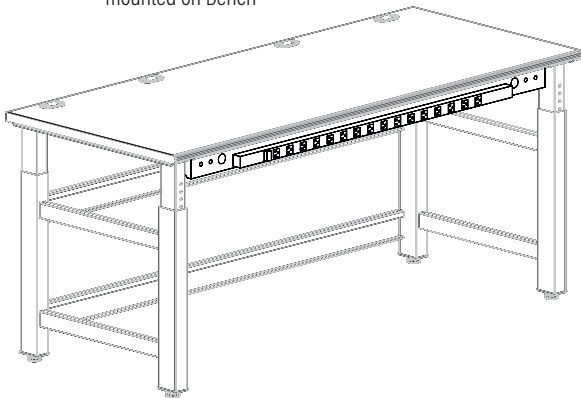

## HOW TO SPECIFY

1. Choose service bar width that matches the bench width	2. Choose the service bar finish
48" (8 Outlets)	Powder coat paint color
60" (12 Outlets)	Powder coat paint can be matched to TechWorks bench frame
72" (16 Outlets)	(See options on pg. 2)
19" Universal Service Bar without power strip	

Item No.	Description	Weight (lbs.)	List Price
----------	-------------	---------------	------------

### SERVICE BARS

#### Service Bar with Power Strip

TWSVB48	48"W, 15 AMP Power Strip, 8 Outlets, 15' Cord	8	816.00
TWSVB60	60"W, 15 AMP Power Strip, 12 Outlets, 15' Cord	12	910.00
TWSVB72	72"W, 15 AMP Power Strip, 16 Outlets, 15' Cord	24	1,048.00

#### Universal Service Bar

TWSVBNP	19"W, No Power Strip	3	149.00
---------	----------------------	---	--------

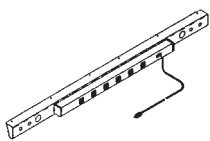

TWSVB60

# TELECOM CHANNELS AND PLATES FOR ORGANIZER FRAMES

TechWorks Telecom Channel mounts to organizer frame upright and accepts up to 3 data plates. (See data plate styles below)

- Not compatible with Corner or L-Shaped organizer frames "inner" sections
- Two blank telecom plates included to cover unused openings
- Multiple data plate configurations available
- To convert USB from inline to charging add: Item TAETP27 USB Transformer

Telecom Channel shown on Organizer Frame

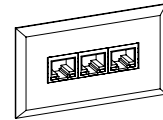
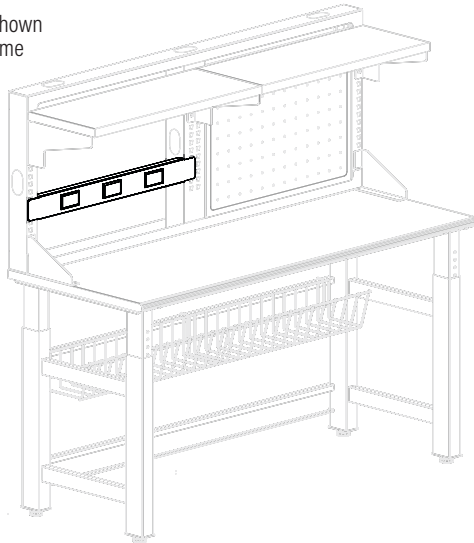

TAETP3

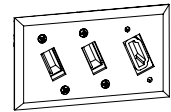

TAETP24

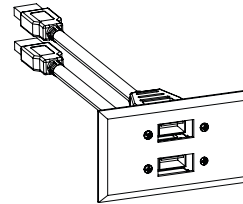

TAETP25

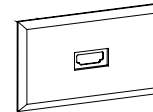

TAETP26



TAETP27

Telecom Plates - see table below for descriptions

## HOW TO SPECIFY

1. Choose the telecom channel width that matches the organizer frame section	2. Choose the data plate inserts	2. Choose telecom channel finish
24"	Choose up to 3 plates per telecom channel TAETP3 TAETP25 TAETP24 TAETP26	Powder coat paint color
30"		Powder coat paint can be matched to TechWorks organizer frame
36"		(See options on pg. 2)

Item No.	Description	Weight (lbs.)	List Price
----------	-------------	---------------	------------

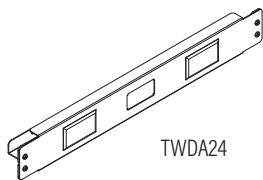

TWDA24

## TELECOM CHANNELS AND PLATES

### Telecom Channels

TWDA24	24"W x 3"H, Telecom Channel	4	253.00
TWDA30	30"W x 3"H, Telecom Channel	4	271.00
TWDA36	36"W x 3"H, Telecom Channel	5	286.00

### Telecom Plates

TAETP3	Plate with 3 RJ45 CAT6 Ports	2	369.00
TAETP24	Plate with 2 USB 3.0 Type A/A with 36" Patch Cord with Male End and 1 HDMI with 36" Patch Cord	2	632.00
TAETP25	Plate with 2 USB 3.0 Type A/A with 36" Patch Cord with Male End	2	455.00
TAETP26	Plate with 1 HDMI with 36" Patch Cord	2	189.00
TAETP27	Transformer with 2 USB-A and 1 USB-C Inputs	2	81.00

# OVERHEAD LIGHT FOR ORGANIZER FRAMES

Techworks Overhead Adjustable-Height and Fixed-Height Lights feature LED bulbs and provide high efficiency lighting for general tasks. Overhead Lights are UL and CSA approved and include an on/off switch and a 9' power cord.

## ADJUSTABLE-HEIGHT OVERHEAD LIGHT

- Light available in black only, light mounting bracket can be matched to organizer frame
- Allow 15" of clearance above frame for height-adjustable lights
- Adjustable overhead lights may interfere with the placement of components at the upper most mounting positions - not compatible with overhead storage bins
- Compatible with back-to-back shared organizer frame applications
- Not compatible with corner or L-shaped organizer frames

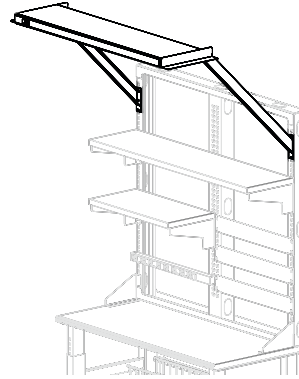

Adjustable-Height Overhead Light

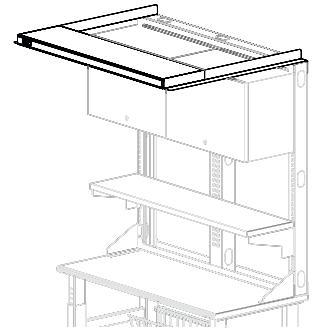

Fixed-Height Overhead Light

## FIXED-HEIGHT OVERHEAD LIGHT

- Light available in black only, light mounting bracket can be matched to organizer frame
- Not compatible with back-to-back shared organizer frame applications
- Not compatible with corner or L-shaped organizer frames

## HOW TO SPECIFY

1. Choose the type of overhead light fixture	2. Choose the overhead light width that matches the organizer frames total width		3. Choose the overhead light mounting bracket finish
Adjustable-Height Overhead Light	36"	60"	Powder coat paint color
Fixed-Height Overhead Light	48"	72"	Powder coat paint can be matched to TechWorks organizer frame (See options on pg. 2)

Item No.	Description	Weight (lbs.)	List Price
----------	-------------	---------------	------------

## OVERHEAD LIGHTS

### Adjustable-Height Overhead Light

TWOHADLT36	36"W, LED Adjustable-Height Overhead Light	36	1,127.00
TWOHADLT48	48"W, LED Adjustable-Height Overhead Light	41	1,280.00
TWOHADLT60	60"W, LED Adjustable-Height Overhead Light	47	1,355.00
TWOHADLT72	72"W, LED Adjustable-Height Overhead Light	50	1,392.00

### Fixed-Height Overhead Light

TWOHFXT36	36"W, LED Fixed-Height Overhead Light	36	1,075.00
TWOHFXT48	48"W, LED Fixed-Height Overhead Light	41	1,228.00
TWOHFXT60	60"W, LED Fixed-Height Overhead Light	45	1,303.00
TWOHFXT72	72"W, LED Fixed-Height Overhead Light	47	1,340.00

## UNDER SHELF/CABINET TASK LIGHTING

Techworks under shelf task lights feature LED bulbs and provide focused high efficiency lighting for general tasks. Under shelf task lights are UL and CSA approved and include an on/off switch.

- Under shelf lighting includes wood screws, double sided tape and magnets for mounting
- EZDP includes capacitive touch On/Off switch and 6' power cord
- 1019WH includes dimmer and 30-minute occupancy sensor

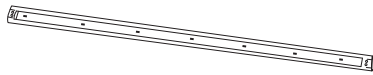

EZDP

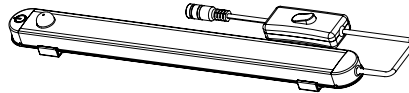

1019WH

Item No.	Description	Weight (lbs.)	List Price
<b>UNDER SHELF LIGHTING</b>			
EZDP	16"W, LED Under Cabinet Light	1	337.00
1019WH	17"W, LED Under Cabinet Light, White	1.5	112.00

## TASK LIGHTING

TechWorks LED Task Lights feature seven adjustable levels for energy-efficiency and perfect internal counterbalance for effortless one-touch positioning for ergonomic function. Task lights are UL and CSA approved.

- Advanced Task Light (Item TWTLA) 3000K color temperature
- Basic Task Light (Item TWTLB) 3500K color temperature
- Advanced Task Light features a PIR occupancy sensor that automatically turns the light off when not in use, and back on when the use returns
- Lights available in Sliver only, mounting plate can be matched to organizer frame

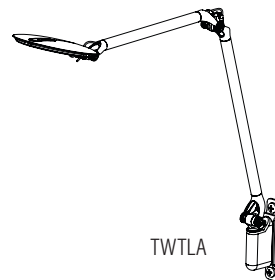

TWTLA

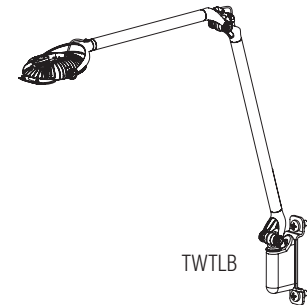

TWTLB

### HOW TO SPECIFY

1. Choose the task light	2. Choose the task light mounting plate finish
TWTLA	Powder coat paint color Powder coat paint can be matched to TechWorks organizer frame (See options on pg. 2)
TWTLB	

Item No.	Description	Weight (lbs.)	List Price
<b>TASK LIGHTING</b>			
TWTLA	Advanced LED Task Light - 3000K Color Temperature	3	995.00
TWTLB	Basic LED Task Light - 3500K Color Temperature	3	561.00

## FLAT PANEL MONITOR ARMS FOR ORGANIZER FRAME

TechWorks gas spring monitor arms attach to the organizer frame and support monitors and accessories weighting up to 176 lbs. and or 32" per monitor. Arms feature +90°~-45° tilt, +90°~-90° swivel and +180°~-180° rotation to accommodate your desired viewing position. Single screen monitor arm and dual screen monitor arms available.

- Gas spring perfectly counterbalances the weight of your monitor
- Built in cable management elegantly hides any cables that are attached to displays
- Slide-in 75mm and 100mm VESA mounting plate for quick attachment and detachment
- Dual screen monitor arm not compatible with 24", 30" or 36" organizer frames and must be mounted in the double wide "inner" uprights of the 48", 60", 72" or 96" organizer frames
- Monitor arms available in black only. Mounting plate color must be specified (refer to Techworks paint options on pg. 2)

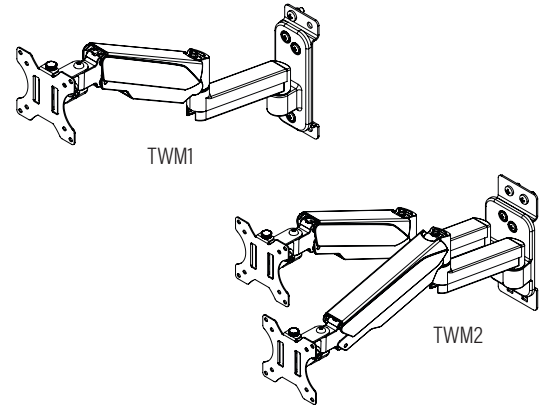

Item No.	Description	Weight (lbs.)	List Price
----------	-------------	---------------	------------

### MONITOR ARMS

TWM1	Single Screen Monitor Arm	6	180.00
TWM2	Dual Screen Monitor Arm	10	277.00

## POLE-MOUNTED CLAMP-ON MONITOR ARMS

Grommet or Tool-less Clamp installation that fits to any work surface up to 3½" thick. Counterbalanced spring technology with easy-to-use Allen wrench adjustment. Slim profiles when in the folded position – ideal for limited work space applications.

- Arms swivel 360° around base allowing for increased display positions
- VESA 75mm and 100mm compliant; TAA compliant
- Cable management system keeps cables hidden
- Available in silver only
- Pole-Mounted
  - 24" of reach and 18" of usable height adjustment (including pole)
  - 4-20 lb. maximum load per each monitor arm
  - Quick connect monitor screen feature

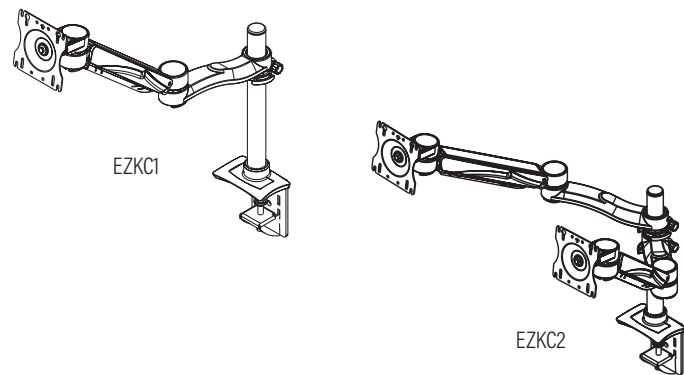

Item No.	Description	Weight (lbs.)	List Price
----------	-------------	---------------	------------

### POLE-MOUNTED MONITOR ARMS

EZKC1	Pole Mount, Single Arm Monitor Mount	8.2	878.00
EZKC2	Pole Mount, Dual Arm Monitor Mount	12.2	1,334.00

# CABLE MANAGEMENT

## CABLE TROUGH FOR ORGANIZER FRAME

- Mounts between organizer frame uprights on the back side of the organizer frame to hold cables in place
- Not compatible with Corner or L-Shaped organizer frames "inner" sections

## VERTICAL CABLE MANAGEMENT FOR ORGANIZER FRAME

- Mounts to the interior of the organizer frame uprights to hold cables in place and conceal cables in the vertical uprights

## CABLE BASKET FOR BENCH MOUNTING

- Mounts to the bench spreader bar on the Techworks bench base to organize and store cables for a cleaner workspace appearance
- Cable Basket available in black only
- Not compatible with TechWorks Electric Height-Adjustable Benches

## HOW TO SPECIFY

1. Choose the type of cable management	2. Choose the cable management finish
Cable Troughs	Powder coat paint color (for cable troughs and vertical cable organizers only)
Vertical Cable Organizers	
Cable Baskets (Black only)	Powder coat paint can be matched to TechWorks organizer frame (See options on pg. 2)

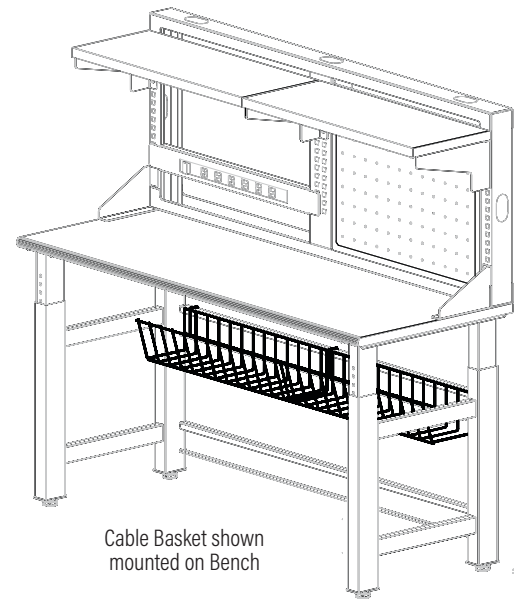

Vertical Cable Organizer shown on Organizer Frame

Item No.	Description	Weight (lbs.)	List Price
----------	-------------	---------------	------------

## CABLE MANAGEMENT

### Cable Troughs

TWCBLTR24	Cable Management 24"W, Horizontal Cable Trough	2	125.00
TWCBLTR30	Cable Management 30"W, Horizontal Cable Trough	3	133.00
TWCBLTR36	Cable Management 36"W, Horizontal Cable Trough	4	149.00

Mounts between organizer frame uprights.

### Vertical Cable Organizers

TWCBLORG24	Cable Management 24"H, Vertical Cable Organizer	2	211.00
TWCBLORG36	Cable Management 36"H, Vertical Cable Organizer	2.5	277.00
TWCBLORG48	Cable Management 48"H, Vertical Cable Organizer	3	376.00

Mounts to interior of frame uprights.

### Cable Baskets

TWCBLBSK48	Cable Management 48"W, Horizontal Cable Basket, Black	4	518.00
TWCBLBSK60	Cable Management 60"W, Horizontal Cable Basket, Black	7	621.00
TWCBLBSK72	Cable Management 72"W, Horizontal Cable Basket, Black	8	763.00

Mounts to spreader on bench base.

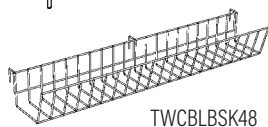
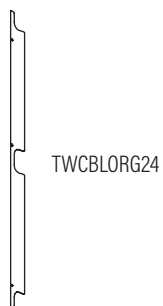
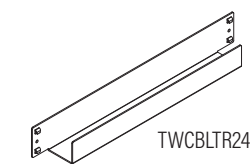

## KEYBOARD TRAYS

Retractable platform keyboard trays mount under the work surface and include keyboard platform, 9.5" diameter mouse tray, and foam wrist rest. Trackless (Item 195TKLS) and track-based (Item 20150BL) models available.

- Item number 195TKL available in black or white

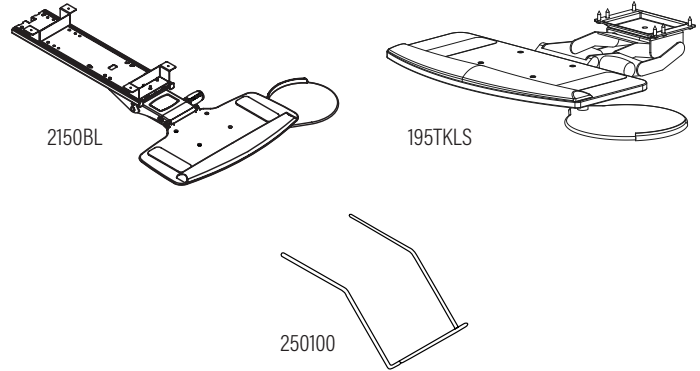
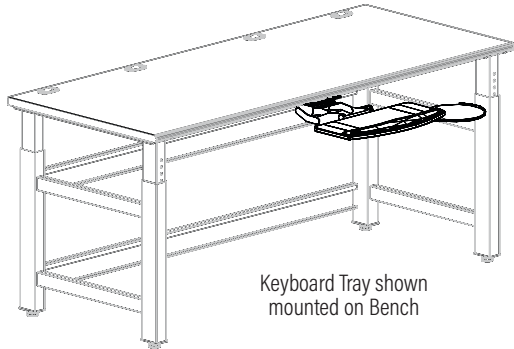

Item No.	Description	Weight (lbs.)	List Price
----------	-------------	---------------	------------

### KEYBOARD TRAYS

2150BL	17"W x 21 3/4"D x 9 1/2"Dia, Trackless Keyboard/Mouse Platform, Black	14	845.00
195TKLS	19"W x 9 1/4"D x 9 1/2"Dia, Trackless Keyboard/Mouse Platform, Black or White	14	859.00
250100	Wire Keyboard Holder, Chrome finish	3	217.00

## HANGING BARS FOR ORGANIZER FRAMES

TechWorks Hanging Bar provides storage for spooled items including 3D printer filament, packaging supplies, and wire. Hanging Bar can be used with straight organizer frames and corner and L-shaped organizer frames "outer" sections only (not compatible with corner organizer frames and L-shaped organizer frames "inner" sections).

- Hanging Bar weight capacity is 100 lbs.
- Hanging bar is adjustable on 1" increments
- Hanging bars install and can be relocated for easy adaptability
- Hanging bar tube is 1 1/2" in diameter

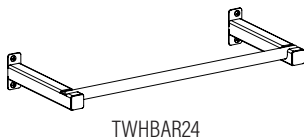

Item No.	Description	Weight (lbs.)	List Price
----------	-------------	---------------	------------

### HANGING BARS

TWHBAR24	24"W, Hanging Bar and Support	10	181.00
TWHBAR30	30"W, Hanging Bar and Support	11	202.00
TWHBAR36	36"W, Hanging Bar and Support	12	224.00
TWHBAR48	48"W, Hanging Bar and Support	14	251.00
TWHBAR60	60"W, Hanging Bar and Support	16	280.00
TWHBAR72	72"W, Hanging Bar and Support	18	307.00

### HOW TO SPECIFY

1. Choose the size of hanging bars		2. Choose the hanging bar finish
24"	48"	Powder coat paint color
30"	60"	Powder coat paint can be matched to TechWorks organizer frame
36"	72"	(See options on pg. 2)



## ESD ACCESSORIES

- Must be wired in compliance with local electrical codes
- Grounding Bar provides common grounding point for managing multiple ground wires
- Wrist Strap must be used with Grounding Jack for proper grounding
- Grounding Jack accommodates 4 standard banana jacks (On the end of Wrist Straps)

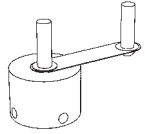

TWESDGRJK

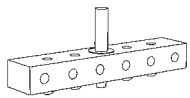

TWESDGRBAR

Item No.	Description	Weight (lbs.)	List Price
<b>ESD ACCESSORIES</b>			
TWESDWR	ESD Wrist Strap	2	145.00
TWESDGRJK	ESD Grounding Jack	3	159.00
TWESDGRBAR	ESD Grounding Bar	0.5	248.00

## RACK MOUNT ADAPTERS

- Provides 19" EIA standard rack mounting between uprights
- Standard with cage nuts for mounting equipment



TWRMA724

Item No.	Description	Weight (lbs.)	List Price
<b>RACK MOUNT ADAPTERS</b>			
TWRMA324	3 ½" Rack Mount Adapter Set (2U) 24" Spacing	2	211.00
TWRMA724	7" Rack Mount Adapter Set (4U) 24" Spacing	3	376.00
TWRMA330	3 ½" Rack Mount Adapter Set (2U) 30" Spacing for 60"W Frames	2	248.00
TWRMA730	7" Rack Mount Adapter Set (4U) 30" Spacing for 60"W Frames	3	407.00

## FLOOR ATTACHMENT BRACKET

- Used to anchor table to the floor
- Hardware not included

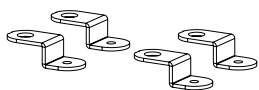

TWFLBRK

Item No.	Description	Weight (lbs.)	List Price
<b>FLOOR ATTACHMENT BRACKET</b>			
TWFLBRK	Floor Attachment Brackets (4), Black	1	113.00

Model No.	Page	Model No.	Page	Model No.	Page	Model No.	Page
195TKLS.....	13, 64	TWB4830ES.....	16	TWBC4836H3.....	20	TWCS3012H3.....	39
1019WH.....	61	TWB4830H3.....	16	TWBC6024BB.....	21	TWCS3018ES.....	39
2150BL.....	64	TWB4830SS.....	16	TWBC6024ES.....	21	TWCS3018H3.....	39
250100.....	64	TWB4836BB.....	16	TWBC6024H3.....	21	TWCS3612ES.....	39
CSH20.....	11, 51	TWB4836ES.....	16	TWBC6030BB.....	21	TWCS3612H3.....	39
EZDP.....	61	TWB4836H3.....	16	TWBC6030ES.....	21	TWCS3618ES.....	39
EZKC1.....	62	TWB4836SS.....	16	TWBC6030H3.....	21	TWCS3618H3.....	39
EZKC2.....	62	TWB6024BB.....	17	TWBC6036BB.....	21	TWCS4812ES.....	39
PH20SF.....	51	TWB6024ES.....	17	TWBC6036ES.....	21	TWCS4812H3.....	10, 39
PH20SM.....	10-11, 13, 51	TWB6024H3.....	17	TWBC6036H3.....	21	TWCS4818ES.....	39
PH20SW.....	9, 51	TWB6024SS.....	17	TWBHA48BB.....	25	TWCS4818H3.....	39
Q629A.....	55	TWB6030BB.....	9, 17	TWBHA48ES.....	25	TWCS6012ES.....	39
Q70800.....	55	TWB6030ES.....	11, 17	TWBHA48H3.....	25	TWCS6012H3.....	39
TAETP3.....	59	TWB6030H3.....	17	TWBHA48SS.....	25	TWCS6018ES.....	39
TAETP24.....	59	TWB6030SS.....	17	TWBHA60BB.....	25	TWCS6018H3.....	39
TAETP25.....	59	TWB6036BB.....	17	TWBHA60ES.....	25	TWCUBBY.....	55
TAETP26.....	59	TWB6036ES.....	17	TWBHA60H3.....	10, 25	TWDA24.....	10, 13, 59
TAETP27.....	59	TWB6036H3.....	17	TWBHA60SS.....	25	TWDA30.....	59
TWB2424BB.....	15	TWB6036SS.....	17	TWBHA72BB.....	25	TWDA36.....	59
TWB2424ES.....	15	TWB7224BB.....	8, 12, 17	TWBHA72ES.....	25	TWDPW2415.....	57
TWB2424H3.....	15	TWB7224ES.....	17	TWBHA72H3.....	25	TWDPW2420.....	57
TWB2424SS.....	15	TWB7224H3.....	17	TWBHA72SS.....	25	TWDPW2420L.....	57
TWB2430BB.....	15	TWB7224SS.....	17	TWBINSTP24.....	9, 49	TWDPW3015.....	57
TWB2430ES.....	15	TWB7230BB.....	17	TWBINSTP30.....	49	TWDPW3020.....	57
TWB2430H3.....	15	TWB7230ES.....	10, 12, 17	TWBINSTP36.....	49	TWDPW3020L.....	57
TWB2430SS.....	15	TWB7230H3.....	9, 17	TWBL24LHBB.....	23	TWDPW3615.....	57
TWB2436BB.....	15	TWB7230SS.....	17	TWBL24LHES.....	23	TWDPW3620.....	57
TWB2436ES.....	15	TWB7236BB.....	17	TWBL24LHH3.....	23	TWDPW3620L.....	57
TWB2436H3.....	15	TWB7236ES.....	17	TWBL24RHBB.....	23	TWDRWR.....	8, 52
TWB2436SS.....	15	TWB7236H3.....	17	TWBL24RHES.....	23	TWESDGRBAR.....	10-12, 65
TWB3024BB.....	15	TWB7236SS.....	17	TWBL24RHH3.....	23	TWESDGRJK.....	10-12, 65
TWB3024ES.....	15	TWB9624BB.....	18	TWBL30LHBB.....	23	TWESDWR.....	10-12, 65
TWB3024H3.....	15	TWB9624ES.....	18	TWBL30LHES.....	23	TWEXP24D.....	54
TWB3024SS.....	15	TWB9624H3.....	18	TWBL30LHH3.....	23	TWEXP30D.....	54
TWB3030BB.....	15	TWB9624SS.....	18	TWBL30RHBB.....	23	TWEXP36D.....	54
TWB3030ES.....	15	TWB9630BB.....	18	TWBL30RHES.....	23	TWFBS2423.....	40
TWB3030H3.....	15	TWB9630H3.....	13, 18	TWBL30RHH3.....	23	TWFBS3023.....	40
TWB3030SS.....	15	TWB9630SS.....	18	TWBL36LHBB.....	23	TWFBS3623.....	40
TWB3036BB.....	15	TWB9636BB.....	18	TWBL36LHES.....	23	TWFBS4823.....	40
TWB3036ES.....	15	TWB9636ES.....	18	TWBL36LHH3.....	23	TWFBS6023.....	40
TWB3036H3.....	15	TWB9636H3.....	18	TWBL36RHBB.....	23	TWFBS7223.....	40
TWB3036SS.....	15	TWB9636SS.....	18	TWBL36RHES.....	23	TWFBS9618.....	40
TWB3624BB.....	16	TWBC2424BB.....	20	TWBOXDRW.....	55	TWFCBS4823.....	41
TWB3624ES.....	16	TWBC2424ES.....	20	TWCASKIT4.....	8, 12, 18, 25	TWFCBS6023.....	41
TWB3624H3.....	16	TWBC2424H3.....	20	TWCASKIT5.....	21, 23	TWFCBS7223.....	41
TWB3624SS.....	16	TWBC3030BB.....	20	TWCBLBSK48.....	63	TWFILEDRW.....	55
TWB3630BB.....	16	TWBC3030ES.....	20	TWCBLBSK60.....	63	TWFLBRK.....	65
TWB3630ES.....	16	TWBC3030H3.....	20	TWCBLBSK72.....	63	TWFP2424.....	47
TWB3630H3.....	16	TWBC3636BB.....	20	TWCBLORG24.....	63	TWFP2436.....	47
TWB3630SS.....	16	TWBC3636ES.....	20	TWCBLORG36.....	63	TWFP2448.....	13, 47
TWB3636BB.....	16	TWBC3636H3.....	20	TWCBLORG48.....	63	TWFP3024.....	47
TWB3636ES.....	16	TWBC4824BB.....	20	TWCBLR24.....	63	TWFP3036.....	11, 47
TWB3636H3.....	16	TWBC4824ES.....	20	TWCBLR30.....	63	TWFP3048.....	47
TWB3636SS.....	16	TWBC4824H3.....	20	TWCBLR36.....	63	TWFP3624.....	47
TWB4824BB.....	16	TWBC4830BB.....	20	TWCS2412ES.....	39	TWFP3636.....	47
TWB4824ES.....	16	TWBC4830ES.....	20	TWCS2412H3.....	39	TWFP3648.....	47
TWB4824H3.....	8, 16	TWBC4830H3.....	10, 20	TWCS2418ES.....	39	TWFP3648.....	47
TWB4824SS.....	16	TWBC4836BB.....	20	TWCS2418H3.....	39	TWFP3648.....	47
TWB4830BB.....	16	TWBC4836ES.....	20	TWCS3012ES.....	39	TWFP3648.....	47

Model No.	Page	Model No.	Page	Model No.	Page	Model No.	Page
TWFPC2624	47	TWPBS9612	40	TWSVB48	58	TWTYP13	13
TWFPC2636	47	TWPCBS4812	41	TWSVB60	9, 58	TWUCF2424	31
TWFPC2648	47	TWPCBS6012	41	TWSVB72	58	TWUCF2436	31
TWFPC3224	47	TWPCBS7212	41	TWSVBNP	58	TWUCF2448	31
TWFPC3236	47	TWPGCM2024	43	TWT3CL	50	TWUCF3024	31
TWFPC3248	47	TWPGCM2036	43	TWT6CL	50	TWUCF3036	31
TWFS2412ES	35	TWPGCM2048	43	TWT9CL	50	TWUCF3048	31
TWFS2412H3	13, 35	TWPGCM2624	43	TWT12CL	50	TWUCF3624	31
TWFS2418ES	35	TWPGCM2636	43	TWT4830BB	27	TWUCF3636	31
TWFS2418H3	35	TWPGCM2648	43	TWT4830ES	27	TWUCF3648	31
TWFS3012ES	35	TWPGCM3224	43	TWT4830H3	27	TWUCF4824	31
TWFS3012H3	35	TWPGCM3236	43	TWT4830SS	27	TWUCF4836	31
TWFS3018ES	35	TWPGCM3248	43	TWT4836BB	27	TWUCF4848	10, 31
TWFS3018H3	35	TWPGCS2024	43	TWT4836ES	27	TWUCF6024	31
TWFS3612ES	35	TWPGCS2036	43	TWT4836H3	27	TWUCF6036	31
TWFS3612H3	35	TWPGCS2048	43	TWT4836SS	27	TWUCF6048	31
TWFS3618ES	35	TWPGCS2624	43	TWT6030BB	27	TWUF2424	29
TWFS3618H3	35	TWPGCS2636	43	TWT6030ES	11, 27	TWUF2436	29
TWFS4812ES	35	TWPGCS2648	43	TWT6030H3	27	TWUF2448	29
TWFS4812H3	8, 35	TWPGCS3224	43	TWT6030SS	27	TWUF3024	29
TWFS4818ES	35	TWPGCS3236	43	TWT6036BB	27	TWUF3036	29
TWFS4818H3	35	TWPGCS3248	43	TWT6036ES	27	TWUF3048	29
TWFS6012ES	35	TWPGM2424	8, 42	TWT6036H3	27	TWUF3624	29
TWFS6012H3	9, 35	TWPGM2436	42	TWT6036SS	27	TWUF3636	29
TWFS6018ES	35	TWPGM2448	42	TWT7230BB	27	TWUF3648	29
TWFS6018H3	35	TWPGM3024	42	TWT7230ES	27	TWUF4824	29
TWFS7212ES	35	TWPGM3036	42	TWT7230H3	12, 27	TWUF4836	8, 29
TWFS7212H3	12, 35	TWPGM3048	9-10, 42	TWT7230SS	27	TWUF4848	13, 29
TWFS7218ES	10, 12, 35	TWPGM3624	42	TWT7236BB	27	TWUF6024	29
TWFS7218H3	9, 35	TWPGM3636	42	TWT7236ES	27	TWUF6036	29
TWGANGLIT	18, 21, 23, 25	TWPGM3648	42	TWT7236H3	27	TWUF6048	9-11, 29
TWHBAR24	64	TWPGS2424	43	TWT7236SS	27	TWUF7224	8, 12, 29
TWHBAR30	64	TWPGS2436	43	TWTH	50	TWUF7236	29
TWHBAR36	64	TWPGS2448	43	TWTLA	61	TWUF7248	9-10, 12, 29
TWHBAR48	64	TWPGS3024	43	TWTLB	9, 61	TWUFBRACE	29, 31, 33
TWHBAR60	64	TWPGS3036	43	TWTS2418ES	37	TWULF24	33
TWHBAR72	64	TWPGS3048	43	TWTS2418H3	37	TWULF36	33
TWM1	8, 13, 62	TWPGS3624	43	TWTS3018ES	37	TWULF48	33
TWM2	10, 62	TWPGS3636	43	TWTS3018H3	37	TWUMODP	54
TWMTRAY24	45	TWPGS3648	43	TWTS3618ES	37	TWWB2424	8, 45
TWMTRAY30	45	TWRMA324	65	TWTS3618H3	37	TWWB2436	9, 45
TWMTRAY36	45	TWRMA330	65	TWTS4818ES	37	TWWB2448	45
TWOHADLT36	60	TWRMA724	65	TWTS4818H3	37	TWWB3024	45
TWOHADLT48	60	TWRMA730	65	TWTS6018ES	37	TWWB3036	45
TWOHADLT60	60	TWSHUFKIT	9, 29	TWTS6018H3	37	TWWB3048	9-10, 45
TWOHADLT72	60	TWSPW2415	10, 13, 57	TWTS7218ES	37	TWWB3624	45
TWOHFXT36	60	TWSPW4815	8, 57	TWTS7218H3	37	TWWB3636	45
TWOHFXT48	60	TWSPW6015	57	TWTYP1	8	TWWB3648	45
TWOHFXT60	60	TWSPW7215	9-10, 12, 57	TWTYP2	8	TWWBC2024	45
TWOHFXT72	60	TWSTASH	55	TWTYP3	8	TWWBC2036	45
TWOHST24	13, 48	TWSTCR24BB	54	TWTYP4	9	TWWBC2048	45
TWOHST30	11, 48	TWSTCR24ES	54	TWTYP5	9	TWWBC2624	45
TWOHST36	48	TWSTCR24H3	54	TWTYP6	10	TWWBC2636	45
TWPBS2412	40	TWSTCR30BB	54	TWTYP7	10	TWWBC2648	45
TWPBS3012	40	TWSTCR30ES	54	TWTYP8	10	TWWBC3224	45
TWPBS3612	40	TWSTCR30H3	54	TWTYP9	11	TWWBC3236	45
TWPBS4812	40	TWSTCR36BB	54	TWTYP10	12	TWWBC3248	45
TWPBS6012	9, 40	TWSTCR36ES	54	TWTYP11	12	TWWRSH20	53
TWPBS7212	40	TWSTCR36H3	54	TWTYP12	12		

---

SAFCO®

# TECHWORKS®

Price List and Specification Guide

[www.safcoproducts.com](http://www.safcoproducts.com)