

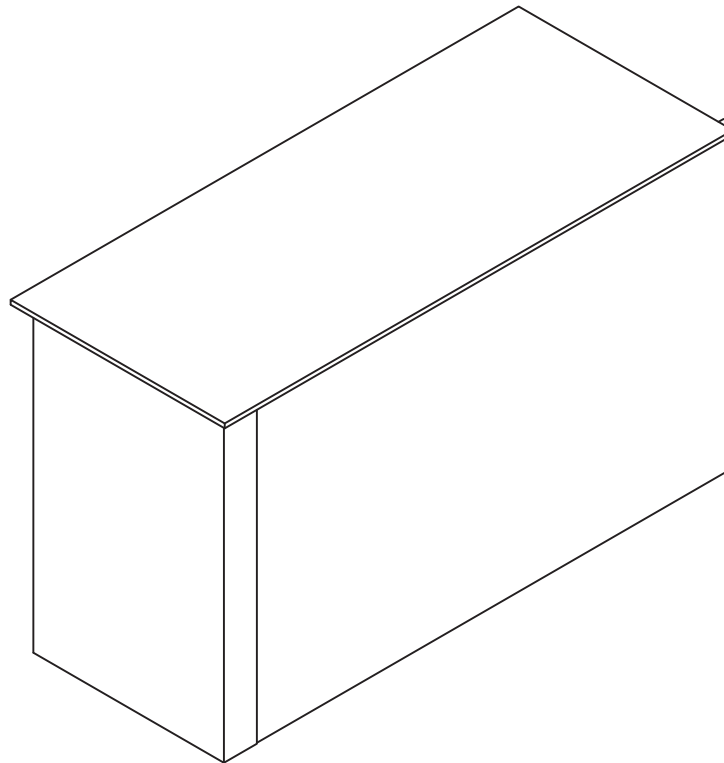



Medina™ Series
Return Desk - Height Adjustable
Model No. MNRTHA



ASSEMBLY INSTRUCTIONS

CALL 1-800-822-8037 FOR ASSISTANCE

PARTS LIST MNRTHA

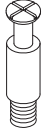
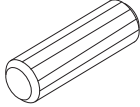
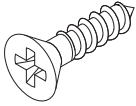
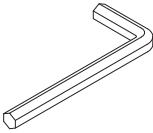
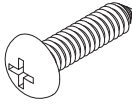
Name	Part	Qty.	Spare Qty
A	 Cam Lock	2	1
B	 REALS102** Cam Sticker	2	1
C	 Cam Post	2	1
D	 Wood Dowel	2	1
E	 4 x 16mm	32	1
F	 Allen Wrench 4mm	1	
G	 5 x 55mm	4	

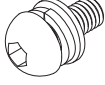
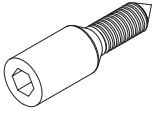
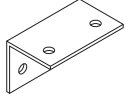
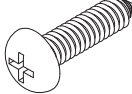
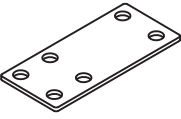
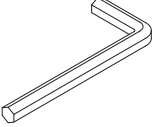
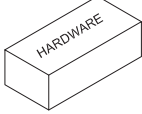
Name	Part	Qty.	Spare Qty
H	 M6 x15mm	9	1
I	 M6 x 33mm	4	1
K	 Corner Bracket	5	
L	 5 x 20mm	3	
M	 Mounting Plate	2	
N	 Allen Wrench 5mm	1	
	 MNRTHAHB		

Items with HB are in hardware box.

**Denotes Color Code

PARTS LIST MNRTHA

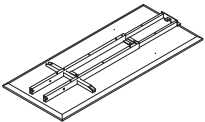
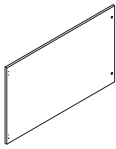
Name	Part	Qty.
O	 Top w/ Frame	1
P	 Fixed Modesty Panel	1

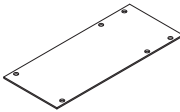
Name	Part	Qty.
Q	 Wire Management Tray	2

PARTS LIST MNRBHA

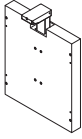
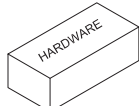
Name	Part	Qty.
R	 <small>HB</small> Leveler	3
S	 Leg	1
	 ABDBHAHB	

NOTE: Carton Contents

- ①. MNRTHA - Top, Modesty Panel and 1 Wire Management Tray w/ hardware.
- ②. MNRBHA - 1 Leg with levelers.

IMPORTANT!

Review ALL instructions before beginning assembly. These instructions are provided to avoid problems that may occur from improper assembly or installation. Mayline and/or its distributor are not responsible for failure resulting from improper assembly or installation of this product. Moreover, all warranties are void for failure to follow these assembly instructions.

- 1 install the Levelers (R) into the Leg (S)

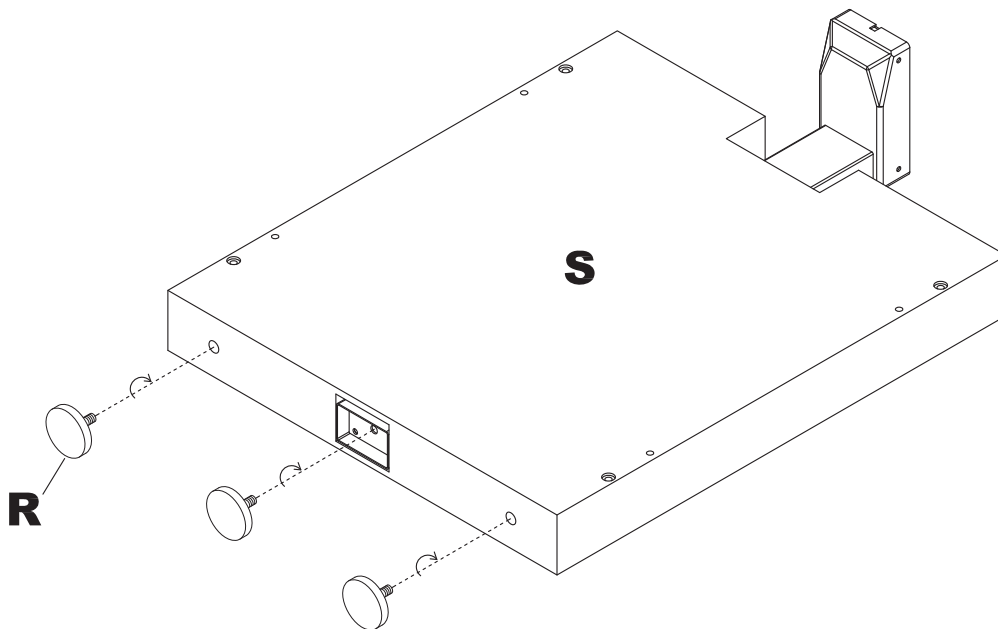

NOTE: The Return Desk can be installed as a Left Handed or Right Handed. Right Handed is shown in the instructions. If Left Hand is desired, attach Modesty Panel (P) to other side of Leg (S) in Step 2.

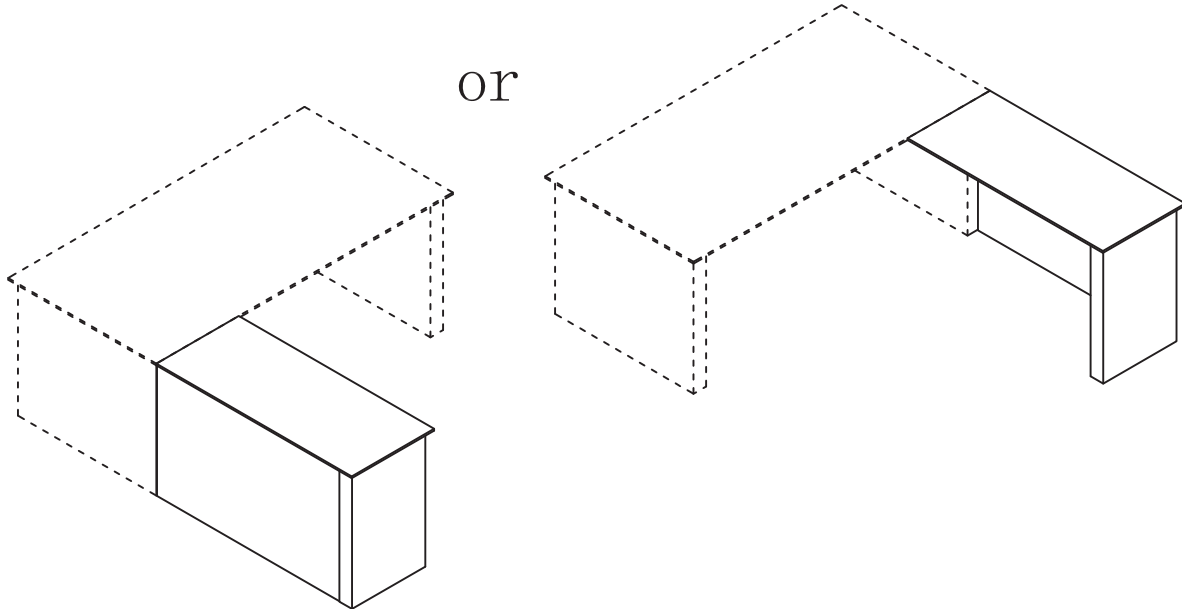

- 2** Insert Wood Dowels (D) and Cams (A) into the Fixed Modesty Panel (P). Install Cam Posts (C) into threaded inserts in Leg (S). Attach Fixed Modesty Panel (P) to Leg (S) by turning Cams (A). Attach Stickers (B) over Cams (A). Attach Bracket (K) to Fixed Modesty Panel (P) and Leg (S) with Screws (E).

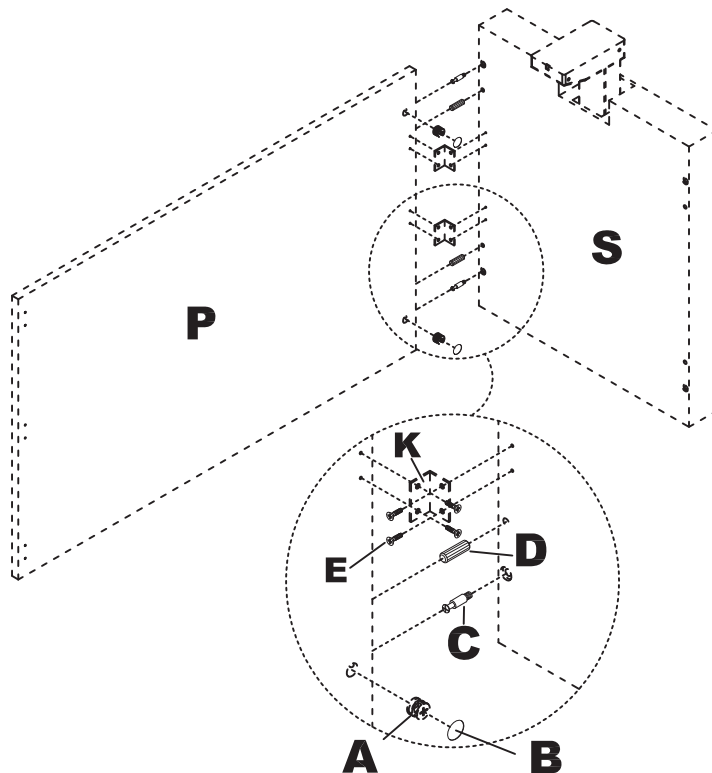

- 3** Install the Top (O) to the Leg (S) using Screw (I) and Wrench (N); Screws pass thru Frame into Actuator Housing on Leg.

The rail is pre-assembled to the bottom of the return top. For a left handed return, the rail must be unscrewed, turned 180 degrees and re-assembled to the return top.

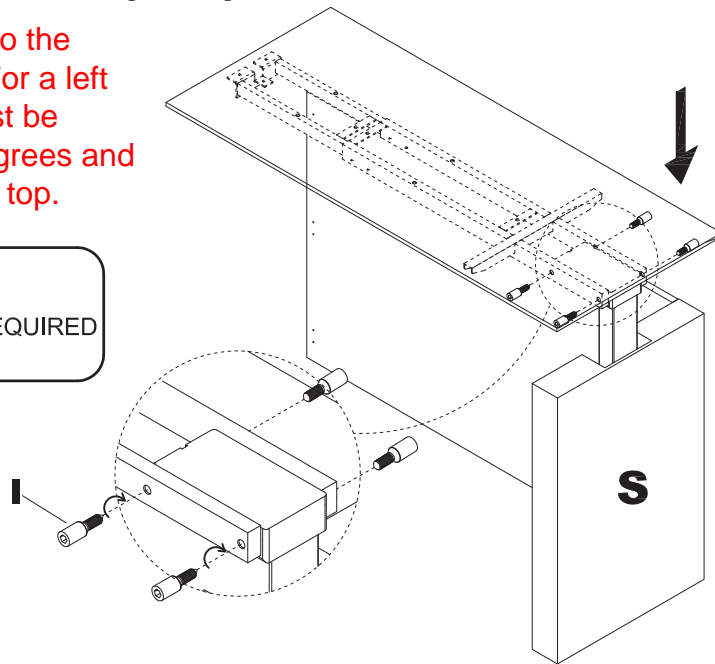

- 4**
- 1- Loosen Screws (H), Extend the Adj Cross Bar to suitable position, re-tighten Screws (H)
 - 2- Use Screws (G/L/H) to attach the Adj Cross Bar/Frame to Top.
 - 3- Use Screw (E) and Corner Bracket (K) to attach the Fixed Modesty Panel (P) and the Leg of the Main Desk. Attach Plate (M) to join Tops using Screws (E)
 - 4- Uninstall the Frame Mounting Screws, Qty 2, using Wrench (F). Install Wire Management Tray to Frame using Screws (H) and Wrench (F). Re-install Frame Screws thru Wire Management Tray.

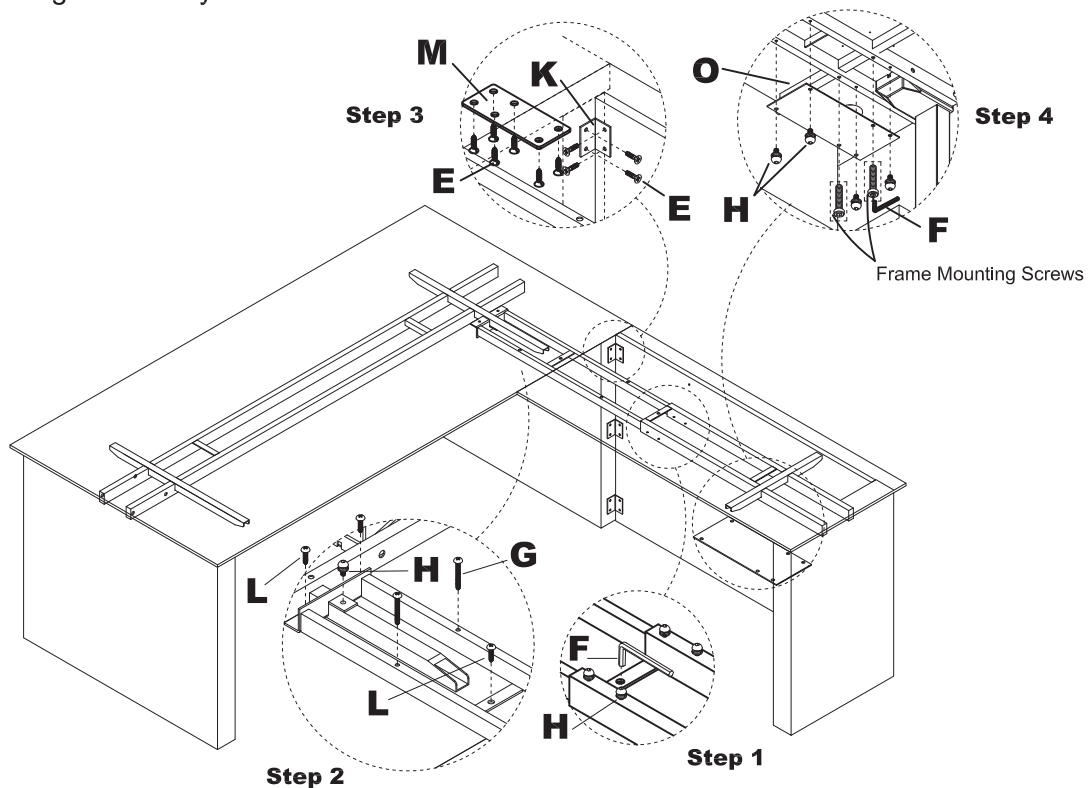

- 5** Install 2nd Wire Management Tray (Q) to Frame using Screws (H) and Wrench (F).

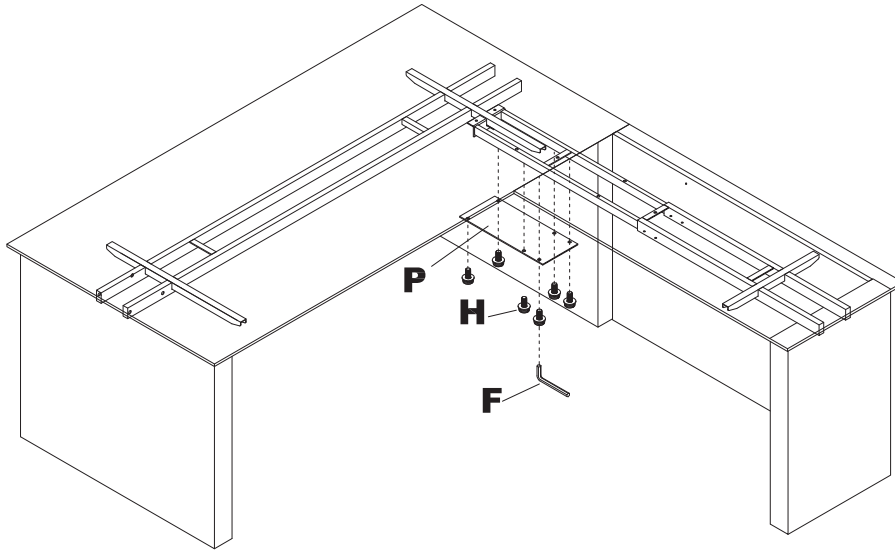

Note: Please make sure to tighten all screws again when the assembly of the desk is finished.



Make sure no obstacles are in the desk's path.

Make sure the desktop is not touching any walls.



Make sure all cords are appropriate length to accommodate the change in height.

IMPORTANT: You must INITIALIZE the desk prior to first use.

Controller Initialization- Press and hold the Down button on the controller until the desk reaches its lowest height, slightly raises, and stops. Release the down button, your desk is now ready for use. (Following the "USER MANUALS" to use your desk)

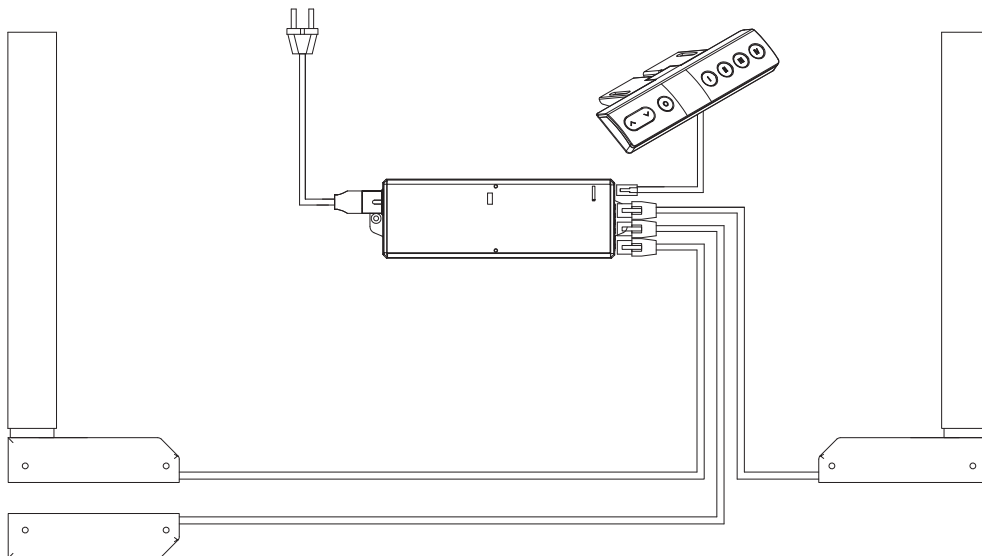

TROUBLESHOOTING

If the table is not functioning properly it may need to be reset. Unplug the power cord for 20 seconds. Plug the power cord back in and follow the RESET procedures;

If the error message persists after the reset procedure, please contact your dealer;

If the height between the legs exceeds 1.5 inches, stop the reset procedure, please contact your dealer;